

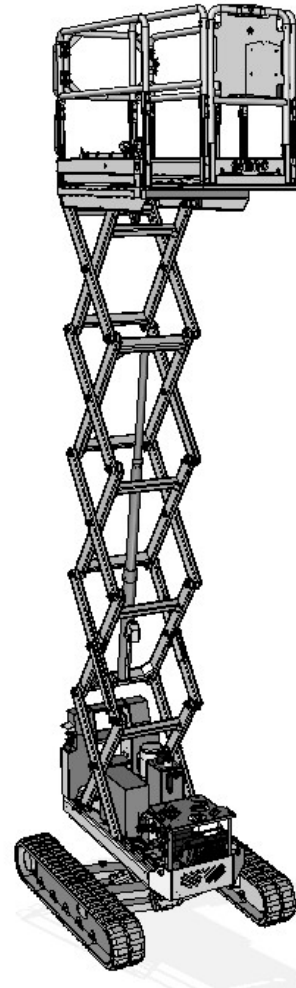

ATHENA

ORIGINAL



ATHENA 850

Bi-levelling Mobile Elevating Work

USE AND MAINTENANCE MANUAL



Please read this user manual carefully before using the machine.

		Data	Ente
Edizione	00	29-03-2016	ET team snc
	01	31/05/2016	ALMAC
	02	19/07/2016	ALMAC

Table of contents

Chap. 1 General information

- 1.1 Documentation supplied
- 1.2 Details of the manual
 - 1.2.1 Recipients
- 1.3 Ownership of the information
- 1.4 Manufacturer's identification data
- 1.5 MEWP identification data
- 1.6 Performance
- 1.7 CE Declaration of conformity
- 1.8 Warranty
 - 1.8.1 Request for interventions during warranty period and formalities.
- 1.9 Assistance
 - 1.9.1 Request for assistance and repairs
- 1.10 Use of the manual
- 1.11 Intended use and improper uses
 - 1.11.1 Intended use
 - 1.11.2 Improper uses
 - 1.11.3 Cases that relieve the manufacturer from liability

Chap. 2 Safety information

- 2.1 Notification of commissioning and routine inspections
- 2.2 Fitness of the personnel
- 2.3 Indicator plates
 - 2.3.1 Instruction plates
 - 2.3.2 Warning, command, danger, identification and instruction signs
 - 2.3.3 Meanings of the sign pictograms
- 2.4 Provisions and prohibitions
- 2.5 Transport and loading
- 2.6 Inspections before use
- 2.7 Inspections during use
- 2.8 Precautions when work terminates or is interrupted
- 2.9 Safety regulations during maintenance
- 2.10 Personal Protective Equipment (PPE)

Chap. 3 Machine description

- 3.1 Structure of the machine**
 - 3.1.1 Main parts of the machine**
- 3.2 Operator interface**
 - 3.2.1 Pushbutton panel lights and controls**
 - 3.2.2 Ground controls**
- 3.3 Safety devices**
 - 3.3.1 Chassis inclination monitoring device**
 - 3.3.2 Work platform elevation monitoring device**
 - 3.3.3 Hydraulic pressure limiting devices**
 - 3.3.4 Hydraulic pressure limiting devices**
 - 3.3.5 Power (electric) cut-out devices**
 - 3.3.6 Hydraulic failure safety devices**

Chap. 4 Instructions for use

- 4.1 Preliminary operations**
 - 4.1.1 Ground fitness for permitted inclination**
 - 4.1.2 Action of the wind**
 - 4.1.3 Basket access**
 - 4.1.4 Basket extension**
 - 4.1.5 Starting**
 - 4.1.6 Emergency starting**
 - 4.1.7 Electric motor starting**
 - 4.1.8 Folding the railings**
- 4.2 Machine operation**
 - 4.2.1 Drive and steering**
 - 4.2.2 Platform levelling**
 - 4.2.3 Basket ascent/descent**
 - 4.2.4 Manual warning buzzer**
 - 4.2.5 Timer.**
 - 4.2.6 Easy-Drive System (ED-S).**
 - 4.2.7 Direct-Control System (DC-S).**
- 4.3 Ground control with mobile pushbutton panel**
- 4.4 Use of ground controls**
- 4.5 Stopping the machine**
 - 4.5.1 Normal stopping**

- 4.5.2 Emergency stop
- 4.6 220 V electrical socket
- 4.7 Storage compartment and documents

Chap. 5 Emergency procedures

- 5.1 Emergency manual descent
- 5.2 Transport of the machine in an emergency

Chap. 6 Maintenance

- 6.1 General maintenance
- 6.2 Checking and tightening screws, bolts, nuts, plug ring nuts
- 6.3 Visual and structural inspection
- 6.4 Damage to tubes and cables
- 6.5 Greasing of articulations and runners
- 6.6 Hydraulic tank oil level inspection
- 6.7 Hydraulic tank oil changes
- 6.8 Inspection of lift circuit pressure relief valve operation
- 6.9 Battery
 - 6.9.1 General recommendations
 - 6.9.2 Maintenance
 - 6.9.3 Recharging
- 6.10 Hydraulic filter replacement
 - 6.10.1 Discharge filter replacement
 - 6.10.2 Return filter replacement
- 6.11 Inspection of inclinometer operation
- 6.12 Verify functionality of the electronic positioning inclinometer
- 6.13 Electrical insulation monitoring device operation test
- 6.14 Manual emergency device operation test
- 6.15 Engine oil inspection and changing
- 6.16 Air filter cleaning and replacement
- 6.17 Spark plug inspection and replacement
- 6.18 Track inspection and tensioning
- 6.19 Track inspection and replacement
- 6.20 Track reduction gear oil level inspection
- 6.21 How to clean the machine
- 6.22 Refuelling

Chap. 7 Demolition

7.1 Demolition

Appendices

- **App. 1 - Declaration of conformity (facsimile)**
- **App. 2 Report register**
- **App. 3 Property transfers**
- **App. 4 Hydraulic diagram**
- **App. 5 Circuit diagram**

General information

1.1 Documentation supplied.

- CE Declaration of conformity
- Instruction Manual (this manual)
- Wiring diagrams and hydraulic layouts
- Report register

1.2 Details of the Manual

- Instruction manual *Elevating work platform*
- Model: *ATHENA 850*

Note: Some of the photos and illustrations may not refer specifically to the version of the machine in your possession, but provide indications concerning the purpose for which they have been included.

1.2.1 Recipients

- User
- Maintenance technician



Attention: the servicing personnel must be properly trained and experienced.



CAREFULLY READ this manual before performing any operation on the machine. If in doubt, do not improvise. Call the assistance service.

1.3 Ownership of the information

This document contains confidential information. All rights are reserved.

This manual may be neither partially nor totally duplicated without the prior written authorization of ALMAC s.r.l.

This document may only be used by the customer to whom the manual has been supplied along with the machine, and only for the purpose of use and maintenance of the machine to which the manual refers.

ALMAC s.r.l. hereby declares that the information in this manual is congruent with the technical and safety specifications of the machine to which the manual refers. The manufacturer declines all liability for direct or indirect damage to persons, things or animals deriving from use of the machine in conditions differing from those envisaged.

ALMAC s.r.l. reserves the right to make changes or improvements, without prior notice, to the documentary material and to the machines, including marketed machines of the same model as that to which this manual refers but with a different serial number.

The information contained in this manual refers in particular to the equipment specified in *1.6 MEWP identification data* and the related documentation

1.4 MANUFACTURER'S IDENTIFICATION DATA

ALMAC S.r.l.

Viale Ruggeri 6/A

42016 – Guastalla (RE) - Italy

email: info@almac-italia.com

Tel. +39 0522-1495846

VAT No. and Tax Code 02559800350

1.5 MEWP identification data

The machine named ATHENA 850 is defined according to current technical standards (ref. UNI EN 280:2013) as:

- **Mobile Elevating Work Platform (MEWP), belonging to group B, type 3 (point 1.4-EN 280)**

Meanings:

GROUP B: All mobile elevating work platforms that differ from those in "Group A" (mobile elevating work platforms in which the vertical projection of the centre of the platform area in all configurations of the platform at maximum inclination of the frame as specified by the manufacturer is always within the tipping lines).

TYPE 3: MEWPs in which movement with the platform lifted is controlled by a command post in the basket.

ASPAC GROUP ELEVATING WORK PLATFORM			
MANUFACTURER		ALMAC s.r.l.	
MODEL	ATHENA 850	SERIAL NUMBER	ALM-000330
YEAR OF MANUFACTURE	2016	UNLADEN WEIGHT WITH TRACKS	2020 Kg
DATE OF TEST			
RATED LOAD INC. 2 OCCUPANT & TOOLS			250 kg
MAX ALLOWABLE SIDE FORCE			40 daN
MAX WIND SPEED			12,5 m/s
MAX PLATFORM HEIGHT			5,99 mt
MAX WORKING HEIGHT			7,99 mt
MAX HORIZONTAL WORKING OUTREACH			1,01 mt
MAX UPPER GRADIENT IN RUNNING DIRECTION			25° (47%)
COUNTRY OF MANUFACTURE			ITALY
HYDRAULIC PRESSURE (TRAVEL)			190 bar
HYDRAULIC PRESSURE (ELEVATING)			150 bar
BATTERY VOLTAGE			12 V
MAX ALLOWABLE INCLINATION OF CHASSIS			1°
THIS MACHINE COMPLIES WITH			AS 1418.10.2011
STATE DESIGN REGISTRATION NUMBERS			
NSW:	VIC:	SA:	QLD:
Designed and Manufactured by: Almac s.r.l. Via Ruggeri 6/A 42016 Guastalla (RE) Italy		Distributed by: ASPAC GROUP 3/84 Hallam South Road Hallam Vic 3803 Australia	
CAUTION. THIS PLATFORM IS NOT VOLTAGE INSULATED			

Identification plate

Refer to the data on the identification plate for an exact identification of the MEWP.

1.6 Performances

Following how the P.L.E. adjustable in working and transport conditions:

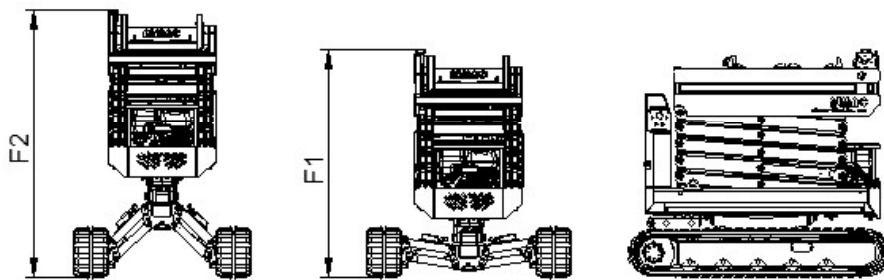
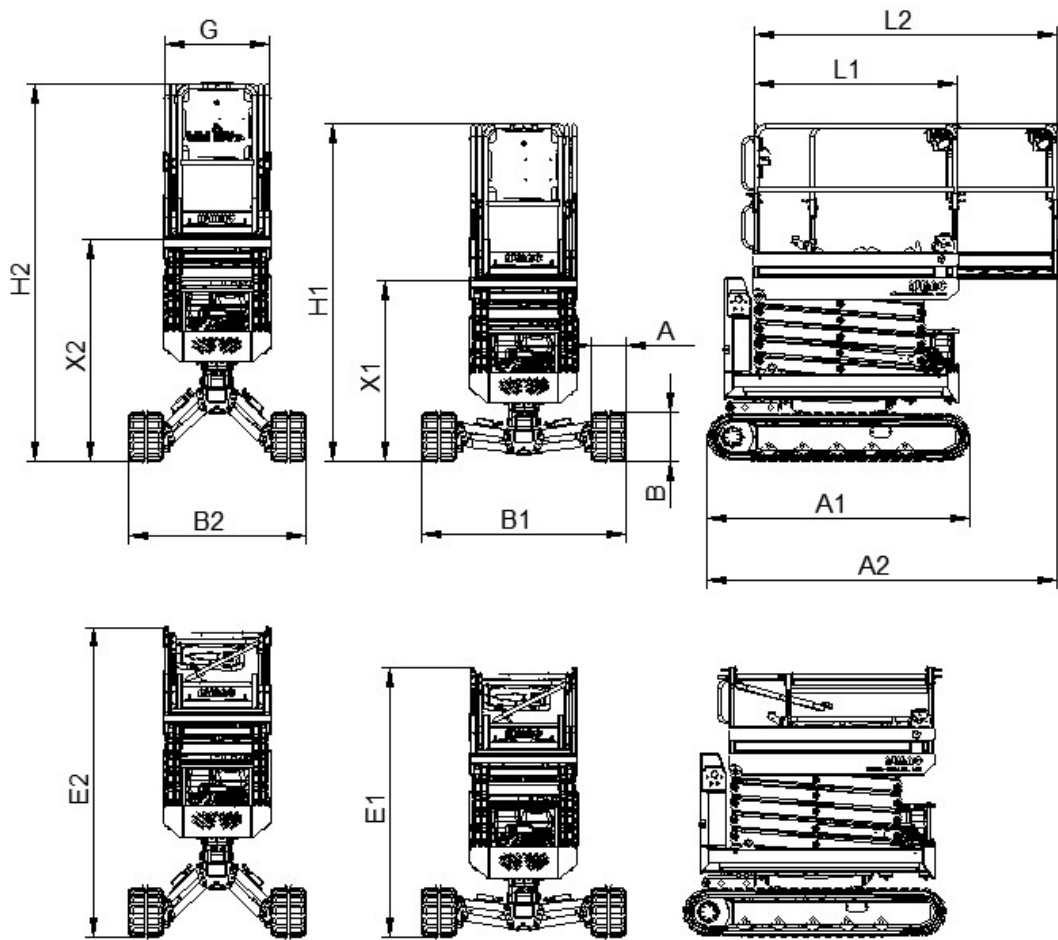

The work platform is provided of foldable guardrails not removable.

Remove and install the guardrails is permitted only for special transport situations and only by specialist maintenance personnel authorized by the manufacturer.

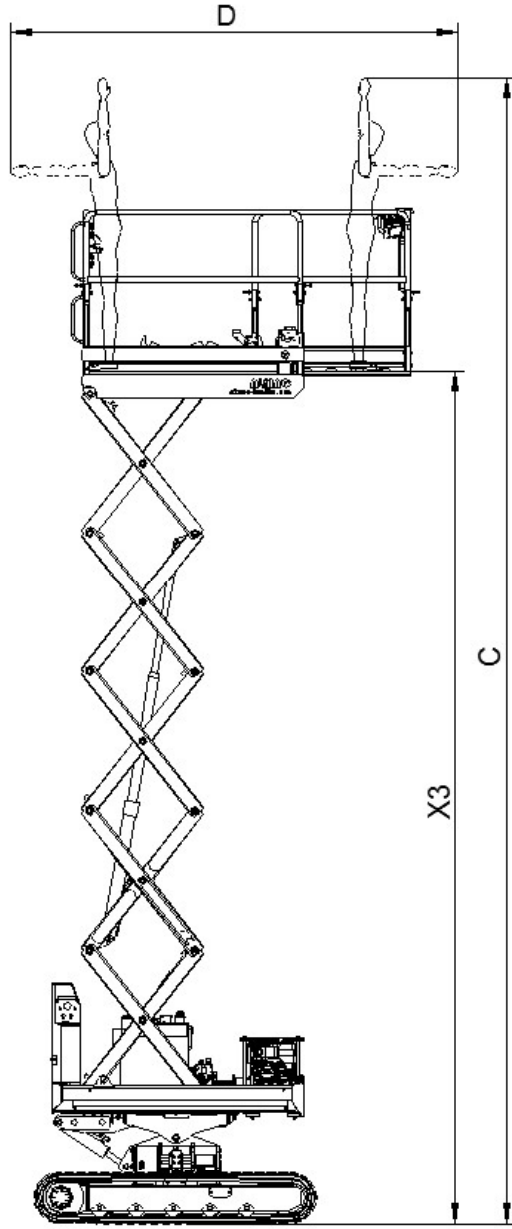
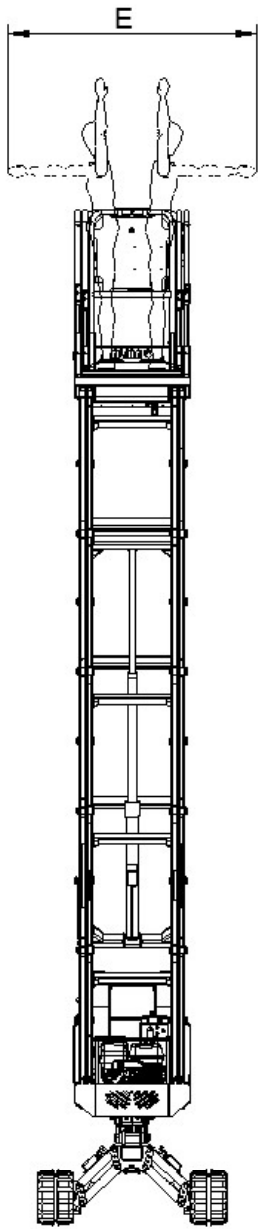

Dimensions		ATHENA 850
Length With basket closed	A1	1.94 m
Length With basket extended	A2	2.58 m
Maximum width Track width	B1	1.50 m
Maximum width Track narrow	B2	1.30 m
Minimum high Track width	H1	2.48 m
Minimum high Track narrow	H2	2.79 m
Basket large	G	0.78 m
Basket large With basket closed	L1	1.50 m
Basket large With basket extended	L2	2.24 m
Tracks sizes	AxB	250 mm x 360 mm
Minimum high floor level Track width	X1	1.34 m
Minimum high floor level Track narrow	X2	1.64 m
Minimum high (only for transport) Track width / guardrails closed	E1	1.98 m
Minimum high (only for transport) Track narrow / guardrails closed	E2	2.28 m
Minimum high (only for transport)	F1	1.68 m
Minimum high (only for transport)	F2	1.98 m
Track min-max	L	1.30 m – 1.50 m
Floor level maximum high	X3	5.87 m
Maximum working level	C	7.90 m
Max. working area (length)	D	3.07 m
Max. working area (large)	E	1.70 m

Specification	ATHENA 850	
Capacity	kg	250
Nr operators onto the basket		2
Lifting time	s	15
Falling time	s	20
Hydraulic pressure	bar	200
Hydraulic oil tank capacity	l	20
Overcame sloop	°	25
Max lateral sloop	°	15
Max longitudinal sloop	°	20 / 16
Speed	km/h	2.0
Weight	kg	2020
Max wind speed admitted	m/s	12.5
Voltage and battery capacity	V/ Ah	12 /50
Battery Weight	kg	15
Noise power Lw	dBA	103
Noise level operator site Lp (inside industrial area)	dBA	84.5 ± 2.6
Noise level operator site Lp (outside on asphalt)	dBA	79.5 ± 2.6
Max peak level L_p peak	dBC	106.0
Hand/arm system vibrations (support operators hands)	m/s²	< 2.5
Full body vibrations (platforms on flat ground)	m/s²	0.52 ± 0.10 *
Hand/arm system vibrations (support operators hands)	m/s²	0.59 ± 0.12 **

* refers on lifted platform (workload) ** refers to the limit of transportation share platform

Standard equipment
Proportional electrohydraulic controls
Internal combustion engine (Honda iGX-390)
Electric Motor 220 V/ 50 Hz
Electrical starter in basket
Electronic accelerator
Electronic tilt control
Overload control
Electronic anti-shearing protection
Electronic hour-counter
Harness anchorage points
Anchorage points and <i>accessories</i> for lifting-transport
Warning buzzer
Inverter, Pure sine wave 1000W In 11-15Vcc Out 220Vac

Engine data	iGX-390	HATZ 1B40-T
Weight	31.7 kg	48 kg
Engine type	4 stroke, head valves, one cylinder automatic accelerator	4 stroke, one cylinder with manual accelerator
Displacement	389 cm ³	462 cm ³
Power	8.7 kW @ 3600 rpm	7.5 kW @ 3600 rpm
Torque	26.5 Nm @ 2500 rpm	25 Nm @ 2500 rpm
Oil (quantity)	1.1 L	1.5 L
Oil tank capacity	6.1 L	5 L
Cooling	air	air

Engine data	Electric
Weight	14 kg
Power	2.2 kW
Torque	10.2 Nm
Rpm	1400
Supply	220 V / 50 Hz
Size IEC	90

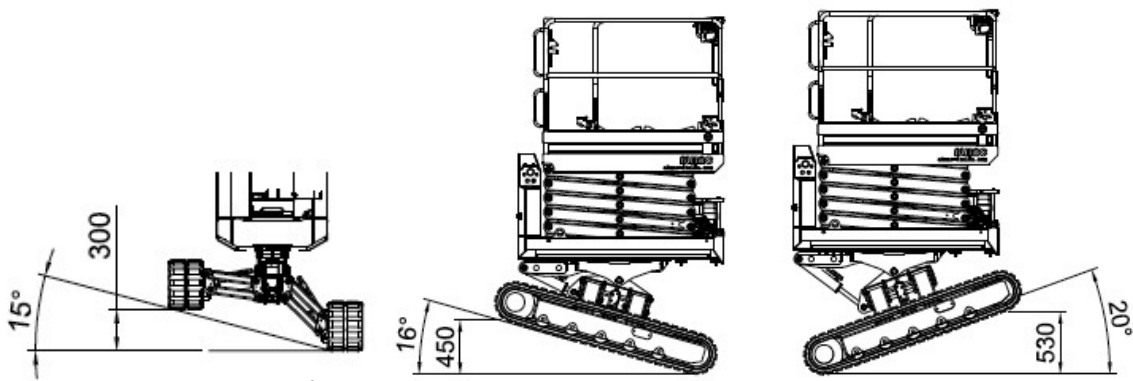

Maximum inclinations allowed

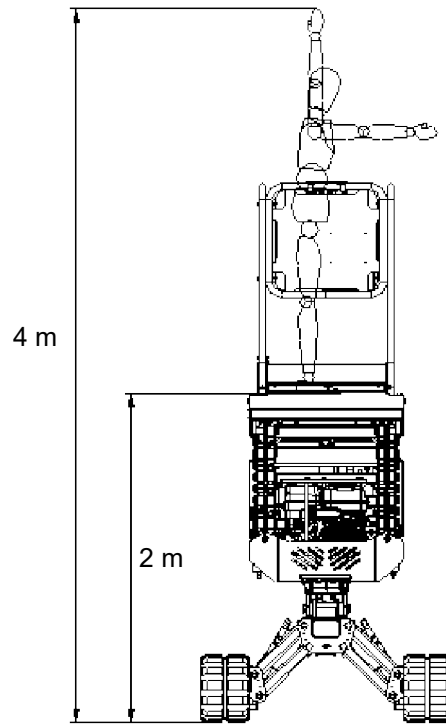

*Maximum admitted transport high
(Manual levelling and the adjustment of the travel speed admitted)*

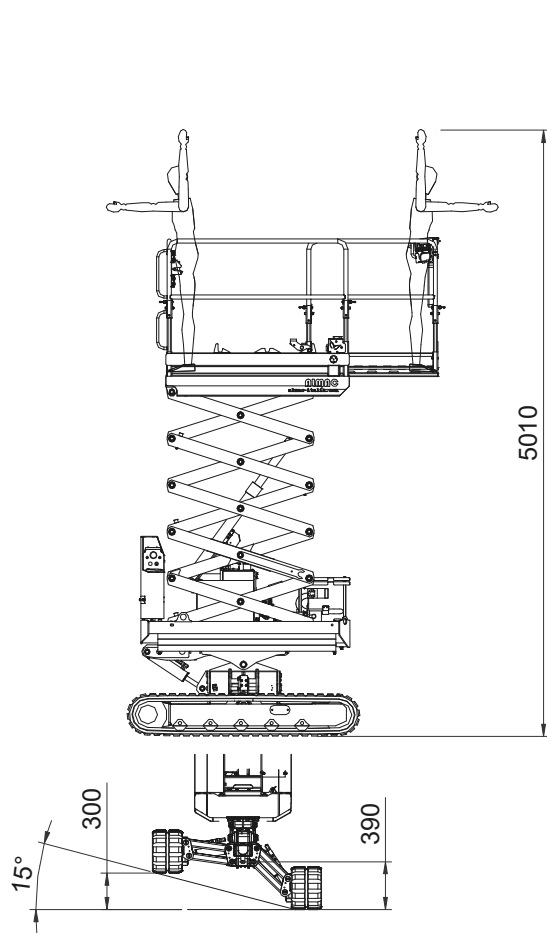

MAXIMUM WORKING HEIGHT WITH TRAVELLING PERMITTED AND UNLIMITED CARRIAGE WIDTH

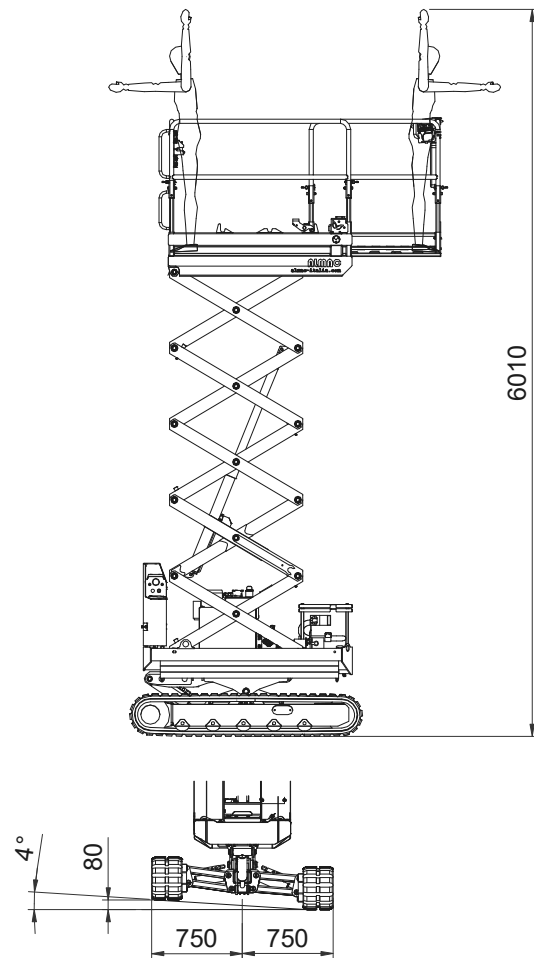

MAXIMUM WORKING HEIGHT WITH TRAVELLING PERMITTED BUT LIMITED CARRIAGE WIDTH

Configurations of translation

1.7 CE Declaration of Conformity

See facsimile of CE declaration of conformity enclosed with this manual.

The machine described in this manual complies with the following standards:

- *Directive 2006/42/EC – Machinery Directive that amends Directive 95/16/EC*
- *Legislative Decree 17/2010 – Implementation of Machinery Directive 2006/42/EC related to the machine*
- *UNI EN 280:2015 - Mobile elevating work platforms - Design calculations - Stability criteria - Construction - Safety - Examinations and tests*
- *UNI EN 349:2008 – Minimum gaps to avoid crushing of parts of the human body*
- *EN ISO 12100:2010 Safety of machinery -General principles for design - Risk assessment and reduction*

All parts available on the market and “partly completed machinery” installed in platform ATHENA 850 conform to the aforementioned Directives and those that specifically govern the product.

1.8 Warranty

ALMAC S.r.l. guarantees the equipment it manufactures and undertakes to replace, free of charge and within the shortest possible time, those parts that, in its opinion, possess manufacturing and/or material defects.

Work under warranty must only be performed by workshops authorized by ALMAC S.r.l. and only when the Customer is up to date with the payments.

The Customer will not be entitled to work under guarantee unless he consigns the equipment for repair within 30 days from the date of the first complaint, to be made in writing.

With the exception of fraud or gross negligence, ALMAC S.r.l. is relieved of all liability towards the Customer for damage deriving from flaws/defects in the traded equipment.

The warranty with which the Customer is provided becomes void if modifications are made to the machines without prior written authorization from ALMAC S.r.l. or should the Customer make incorrect/improper use of the machines.

1.8.1 Request for interventions during warranty period and formalities

ALMAC S.r.l. must be notified of requests for spare parts or technical interventions under guarantee as soon as a defect is discovered.

Always indicate the type of machine and its serial number when requesting spare parts under guarantee or technical interventions under guarantee. This information is given on the equipment identification plate.

1.9 Assistance

As far as the optimum use of the machine and extraordinary maintenance are concerned, this manual does not replace the experience of the Technical Assistance sent by ALMAC S.r.l. (also refer to *Chapter 6 Maintenance*).

1.9.1 Request for assistance and repairs

To request ALMAC S.r.l. specialized Assistance Service, the Customer may contact:

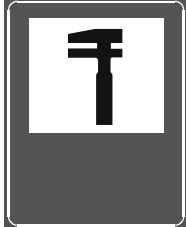

ALMAC S.r.l.
Via Caduti Sul Lavoro 1
46019 - Viadana (MN- Italy
email: info@almac-italia.com
Tel. +39-0375 83 35 27

When requesting assistance interventions, always indicate the model of the machine and its serial number: this data is given on the identification plate.

1.10 Use of the manual



Note: Keep this manual in an accessible place known to all users (operators and maintenance workers).

Note: This manual must be kept in a protected place inside the compartment provided in the basket so that it can be easily accessed for consultation throughout the entire technical life of the machine.

Note: If this manual is lost or damaged, a new copy must be ordered from the manufacturer. Specify the serial number of the machine (given on the relative identification plate) when requesting a new copy of the manual. The manufacturer undertakes to provide a new copy.

Note: When selling used equipment, this manual and the related attachments must be included and the manufacturer must be informed of the new owner (*see Appendix 3 - Transfer of Ownership*)



Read carefully *Chapter 1 General Information*, *Chapter 2 Safety information*, *Chapter 3 Description of the Machine and Performance*, *Chapter 4 Operating instructions*, *Chapter 5 Emergency Procedures*.

Always consult the relative chapter when using, servicing the machine or when it is demolished.

1.11 Intended use and improper uses

1.11.1 Intended use

The ATHENA 850 MEWP described in this manual is a self-propelled elevating work platform designed to lift personnel and equipment for performing the following jobs:

- professional gardening and general work
- installation of systems and equipment
- cleaning
- painting and paint removal

The max capacity for model ATHENA 850 is 250 kg. Consider the following:

- 2 (two) persons each weighing 80 kg
- 90 kg of equipment

An electronic control system prevents the basket from lifting to any position when the load exceeds 20% of the rated load given in the technical specifications.

The platform was designed and built to be driven only from the console in the basket.

The pushbutton control panel is removable and can only be used by the operator to drive the platform only in the TRANSPORT position.

The controls on the ground on the rear side are for EMERGENCY use or MAINTENANCE by qualified personnel.



Attention: NEVER exceed the machine's established maximum capacity.

Attention: It is FORBIDDEN to transport large slabs or materials since this could increase wind resistance to a considerable extent and cause the machine to tip over.

Attention: It is FORBIDDEN to apply horizontal loads to the platform when the machine is on the move (e.g. the operators on board must not pull ropes or cables...)

Attention: It is FORBIDDEN to use the machine for towing other equipment or vehicles.

Attention: the machine is designed for being driven around within public or private areas. It is not designed for road circulation.



Attention: the machine is NOT EQUIPPED TO WORK IN ATEX ATMOSPHERES



ALL LOADS must be positioned inside the basket. NEVER EVER LIFT LOADS HANGING FROM THE PLATFORM or from the lifting structure.

If the machine is used in places open to the public or in construction sites where persons may transit or remain in the vicinity, the WORK AREA MUST BE CORDONED OFF in a suitable way (e.g. chains and posts).

1.11.2 Improper uses

Any other use not specifically indicated in *1.11.1 Intended use*.

- ! **The improper uses established for this MEWP include lifting and lowering persons to/from different storeys within space (typical use of elevators).**
- ! **It is also forbidden to drive the platform on the ground using the mobile pushbutton panel with an operator in the basket.**



The platform was designed and built to be driven only from the console in the basket. The controls on the ground on the rear side are for EMERGENCY use or MAINTENANCE by qualified personnel.

The pushbutton control panel is removable and can only be used by the operator to drive the platform only in the TRANSPORT position.

1.11.3 Cases that relieve the manufacturer from liability

The manufacturer declines all liability in the following cases:

- Use not indicated in this manual
- Improper use of the machine or its use by untrained personnel
- Use that fails to comply with the specific standards
- Lack of scheduled maintenance;
- Unauthorized changes or interventions;
- Removal of seals
- Use of non-original replacement parts
- Total or partial failure to comply with the instructions
- Failure to perform the Routine Inspections required by the laws in force

2.1 Notification of commissioning and routine inspections

The work equipment indicated in Annex VII to Legislative decree 81/2008 and successive amendments must be subjected to REGISTRATION and ROUTINE INSPECTIONS by the competent authorities, i.e. INAIL, the National Institute for Insurance Against Industrial Accidents (former ISPESL, Higher Institute for Prevention in the Workplace), the Local Health Authority and other public and private bodies established by the criteria laid down in Ministerial decree DM 11/04/2011.

- a) The User or Employer must notify Commissioning to the territorially competent National Institute for Insurance Against Industrial Accidents (INAIL) for the purpose of registering the platform.
- b) Once the platform has been registered, ROUTINE INSPECTIONS must begin. The FIRST of these is performed by INAIL within 45 days (since 21 August 2013) from the date on which the platform is put into service.
- c) The successive inspections, to be carried out at the frequency indicated in Annex VII to Legislative Decree 81/2008, are carried out by the Local Health Departments (ASL) or, when permitted by the regional laws, by ARPA (Regional Agency for the Protection of the Environment) or by Public or Private undertakings, as freely decided by the Employer or User and in accordance with the established formalities.

Attached are a few EXAMPLES of "notice of commissioning" and "routine inspections". Users should check them each time in the www.inail.it portal, according to the installation site in question.

2.2 Fitness of the personnel

The operators who use the machine must be properly trained, informed, instructed on how to use the machine in safe conditions and must possess a training certificate issued in accordance with the laws in force at the time of use*.

The operators who use the machine must be over 18 years of age and be recognized as psychophysically fit for the task in question. The following requirements must be ascertained before the operators are allowed to drive the machine:

- sight and hearing in good conditions
- absence of changes induced by use of alcohol or drugs
- psychological equilibrium, absence of depression or stress

Operators who use the machine for professional purposes must undergo health surveillance as required by Legislative decree 81/2008 and successive amendments, particularly with regard to alcohol addiction and alcohol concentration tests.

**The law that currently governs health control and surveillance of workers is the Provision of the State-Regions Permanent Conference of 16 March 2006.*



Note: ALMAC S.r.l. declines all liability for damage to persons, animals and things deriving from:

1. failure to comply with the safety regulations
2. use of the machine by unqualified operators
3. failure to comply with the recommendations in the documentation supplied

Extract from the Italian Laws currently in force: State-Regions Agreement of 22 February 2012, published on 12 March in the Official Gazette

Mobile elevating work platforms				Mobile machine designed to move persons to their work stations, in which they perform their tasks from the work platform; meaning that the persons enter and leave the work platform by means of a defined access position, that consists of at least one work platform with controls, an extensible structure and a frame.
	Legal struct.	Tech. struct.	Pract. struct.	
Mobile elevating work platforms	1	3	4 - on stabilizers 5 - without stabilizers 6 - with and without stabilizers.	

TOTAL=

MEWP

8 h



2.3 Indicator plates

The following sign plates are affixed to the machine:

- Identification (see par. 1.5)
- Instructions
- Command/prohibition sign plates
- Attention
- Danger

2.3.1 Instruction plates



MAX 250Kg =  +  90Kg

Data plate with maximum capacity indication

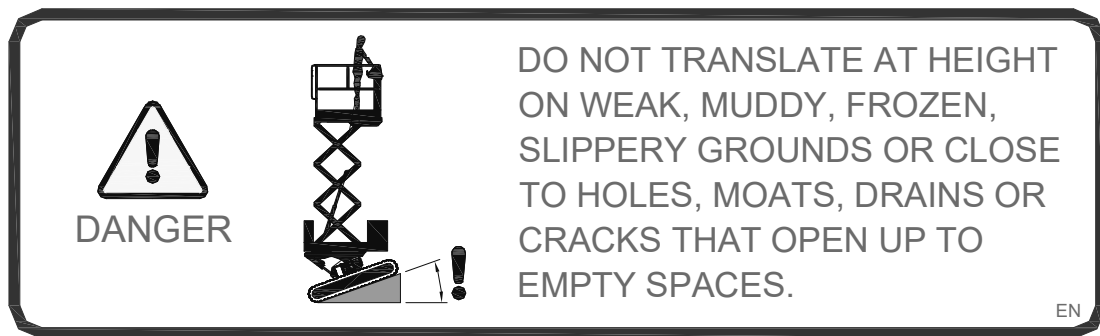
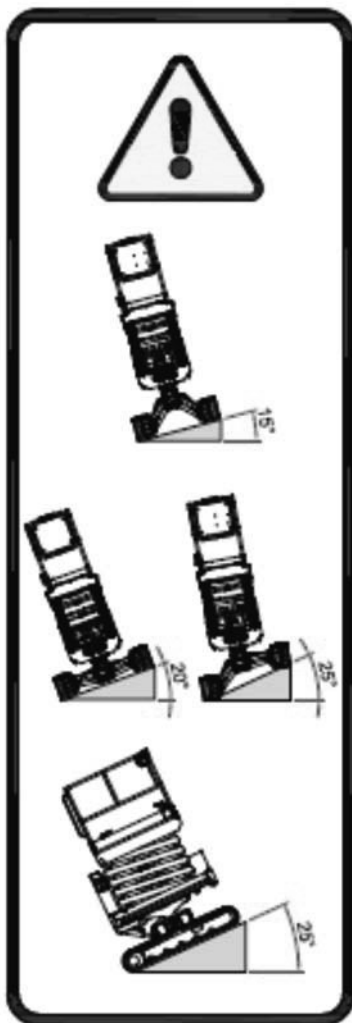

Plate with danger indication for inclined movement on slippery ground



Maximum Terrain Inclination in trasport configuration

- Lateral Min Track Inclination – The maximum safe lateral inclination across the terrain in minimum track width is 15°. There is no electronic device monitoring this and is at the discretion of the operator.
- Lateral Inclination of terrain – The maximum safe lateral inclination of the terrain with the chassis as level as possible is 25°. There is no electronic device monitoring this and is at the discretion of the operator.
- Frontal inclination of terrain – The maximum safe frontal inclination of the terrain is 25°. There is no electronic device monitoring this and is at the discretion of the operator.

Plate with maximum inclinations allowed on dangerous ground to avoid risk of rollover and sliding, with machine in translation and fully lowered

Note: The inclinations listed on the plate above refer to those LIMITS that cannot be exceeded with the machine. Almac s.r.l. has equipped the ATHENA 850 with an electronic monitoring system that prevents machine movements exceeding the maximum inclinations but not in the transport configuration.



THE OPERATOR IS PROHIBITED TO MOVE BETWEEN THE BASKET AND A STRUCTURE OUTSIDE THE MACHINE, MACHINE STABILITY COULD BE JEOPARDISED.

PERSONNEL AND THE EQUIPMENT MUST ENTER AND EXIT THE CAGE ONLY WITH THE SCISSOR IN STOWED POSITION AND BASKET RETRACTED.



THE OPERATOR IS PROHIBITED TO MOVE BETWEEN THE BASKET AND A STRUCTURE OUTSIDE THE MACHINE, MACHINE STABILITY COULD BE JEOPARDISED.

PERSONNEL AND THE EQUIPMENT MUST ENTER AND EXIT THE CAGE ONLY WITH THE SCISSOR IN STOWED POSITION AND BASKET RETRACTED.

EN EN



DANGER

WHEN THE MACHINE RAISED, DO NOT ENTER IN THE SPACE BELOW, UNLESS THE DEVICE SUPPORT ARE IN POSITION.

EN

2.3.2 Warning, command, danger, identification and instruction signs

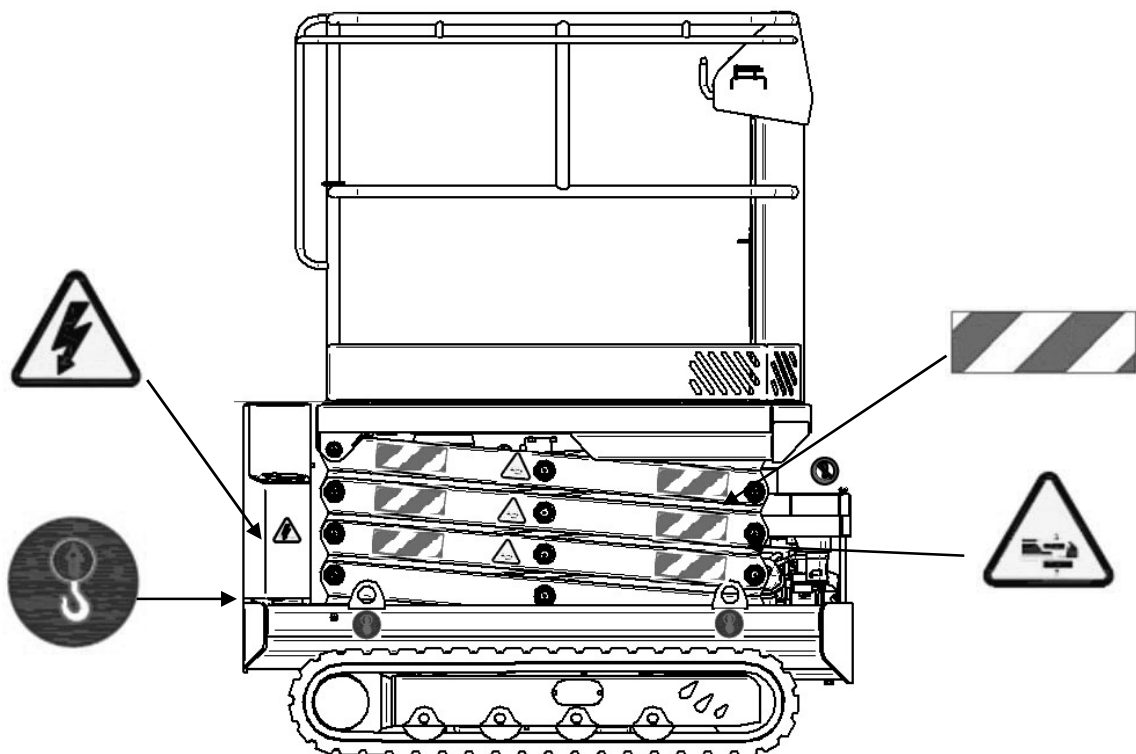
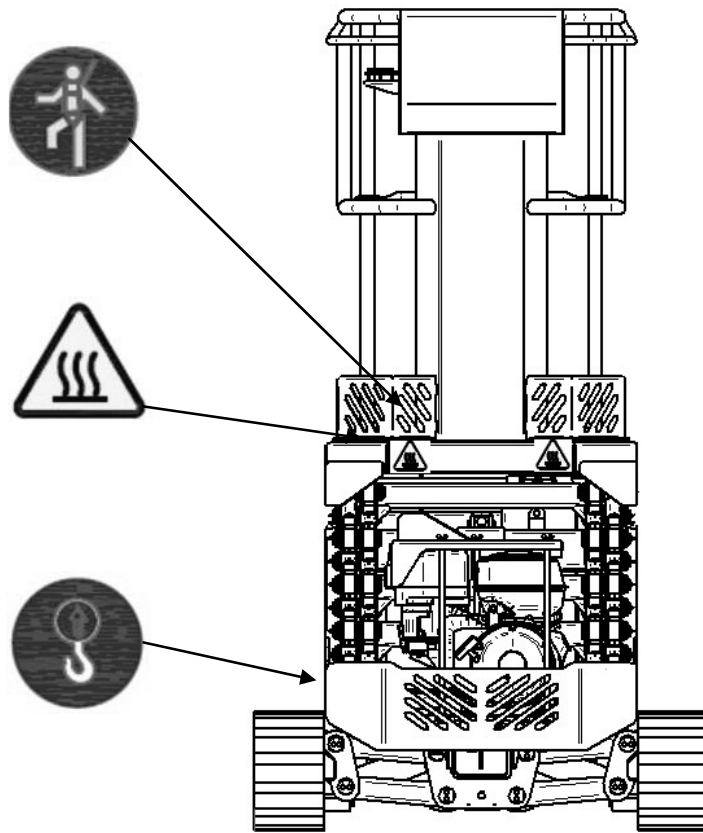

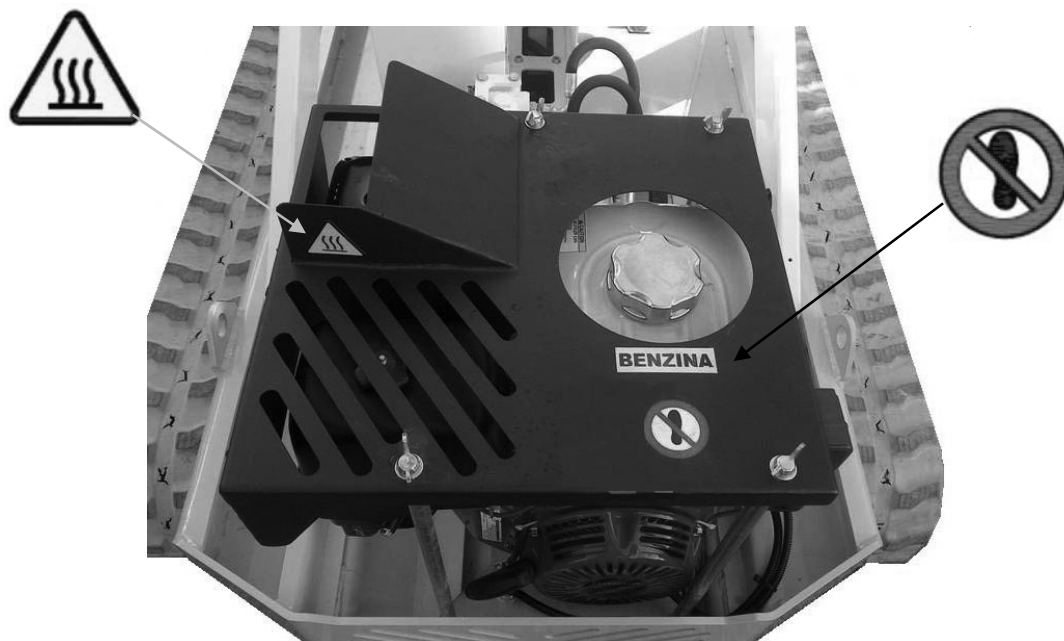
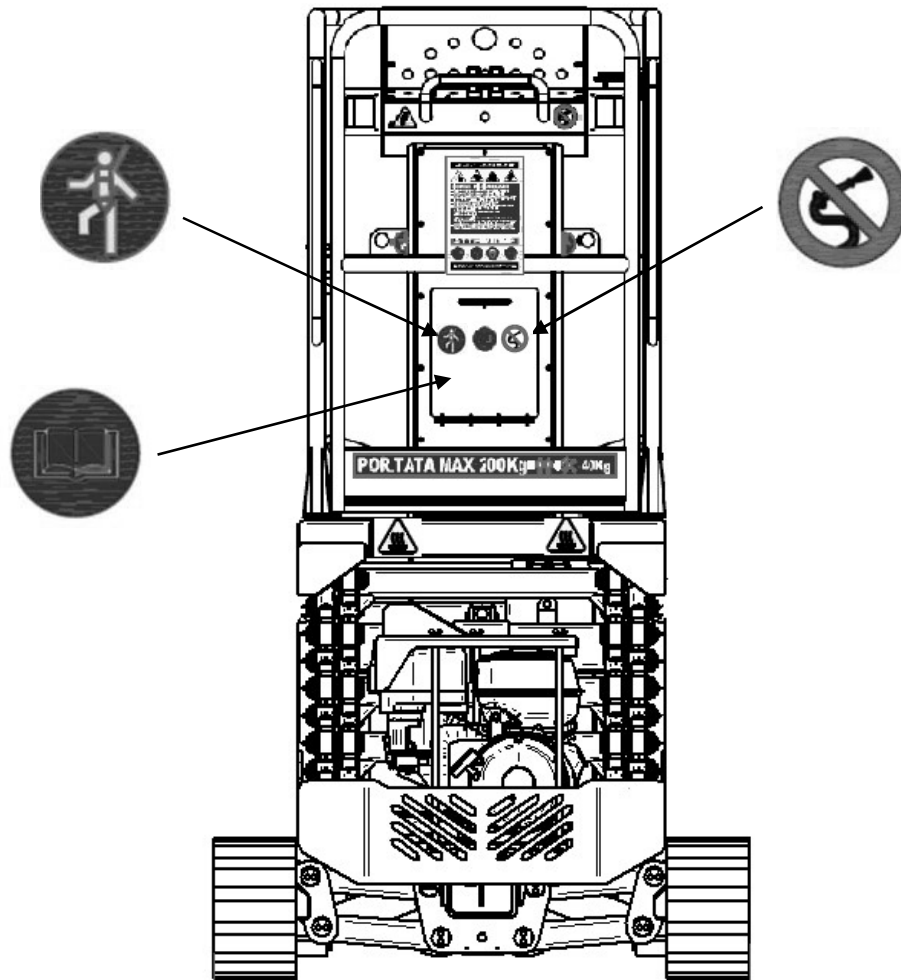













Note: The plates are affixed to the machine for the purpose of helping the operator and/or warning him of the risks to which he may be exposed when he uses the machine. In no way does the information on the plates substitute this Manual, which is the only reference document containing complete information.



Comply with the indications on the sign plates. Failure to comply with these indications may result in serious injuries and even death, and in any case could endanger the operators and/or exposed persons. Make sure that the sign plates are always affixed and legible. If this is not the case, they must be fastened back in place or replaced.

2.3.3 Meanings of the sign pictograms

	Attention / Danger This symbol means that you must take care or that danger is present. Failure to comply with this alert indication could cause damage to the machine, the operator or exposed persons.
	Attention. This symbol means that you must be careful of hot parts that could cause burns. Do not touch.
	Attention. This symbol means that you must take care of an electric panel or other live electrical devices.
	Danger This symbol means that there is a danger of injury to the upper and lower limbs due to moving parts. Do not insert your hands or feet into openings that could move and cut or between moving parts.
	Prohibited Means that it is forbidden to use water at high pressure on these surfaces
	Prohibited Means that it is forbidden to climb onto the parts indicated by this symbol.
	Sign plate Be careful of the moving scissor components.
	Required This sign plate means that you must wear a safety belt on board the work platform and shows where it must be anchored
	Required This symbol means that you must use the indicated anchor points for lifting the machine.
	Required This symbol means that you must comply with the instructions in the “use and maintenance manual”.

2.4 Provisions and prohibitions

- ! Read this manual carefully before starting, using, servicing or performing other operations on the machine.
 - ! The MEWP must always be kept in perfect condition by following the maintenance program described in *Chapter 6 Maintenance*.
 - ! Do not wear rings, wrist watches, jewellery, unfastened or loose clothing such as neckties, torn garments, scarves, unbuttoned jackets or garments with open zip fasteners that could become caught up in moving parts.
 - ! Wear approved safety garments, such as non-slip footwear and a reflective vest.
 - ! To keep the risk of slipping or tripping to the minimum, always keep the operator compartment, platform surfaces, steps, handrails and grip bars clean and free from all foreign objects or traces of oil, mud and snow.
 - ! THE OPERATOR IS PROHIBITED TO MOVE BETWEEN THE BASKET AND A STRUCTURE OUTSIDE THE MACHINE, MACHINE STABILITY COULD BE JEOPARDISED. PERSONNEL AND THE EQUIPMENT MUST ENTER AND EXIT THE CAGE ONLY WITH THE SCISSOR IN STOWED POSITION AND BASKET RETRACTED.
 - ! WHEN THE MACHINE RAISED, DO NOT ENTER IN THE SPACE BELOW, UNLESS THE DEVICE SUPPORT ARE IN POSITION.
 - ! Clean the soles of your footwear before getting on the MEWP.
 - ! Do not use the controls of flexible tubes as handgrips.
 - ! Do not lean over the handrail surrounding the basket.
 - ! Warn the persons in charge of maintenance if the machine operates in a faulty way.
 - ! Make sure that all guards and other protections are positioned correctly and that all the safety devices are installed and efficient.
 - ! Do not use the platform in places where there is a risk of explosion or fire outbreaks.
 - ! Do not use jets of water or high-pressure washers to clean the platform.
 - ! **The** operator on the platform must, according to current safety laws, use a protective HARD HAT and attach the special SAFETY HARNESS to the basket. The operator on the ground must also wear a hard-hat.
- ☀ **USE OF THE PLATFORM ALWAYS REQUIRES 2 OPERATORS, ONE OF WHOM ON THE GROUND and able to perform the emergency operations described in this Manual.**
- ☀ The platform must not be used if there is insufficient light, since it is not fitted with its own lights.
 - ☀ The control box in the basket must always be protected with the casing supplied if it rains or when the machine is parked.

2.5 Transport and loading

You are advised to check the dimensional limits established for means of transport if the machine must be transported to its specific work site (see sect. 1.6-Performance).

The machine can be loaded onto the vehicle in two different ways:

- 1) **Using chutes and the platform movement commands:** with the platform completely LOWERED, the operator can move the machine by following the instructions in PAR. 4.3-STARTING and drive the machine straight onto the vehicle. In this case, make sure that the ramp gradient is within the gradeability indicated in the PERFORMANCE data and that the bearing capacity of the chutes suits the weight of the machine.

Note: the machine has an advanced traction control "**Direction-Control**" (DC-S on the control panel) that lets you move in a straight line using a single joystick. We recommend using this operating move with the platform in track width and after having aligned the chutes (*ref. Par. 4.2.7*)

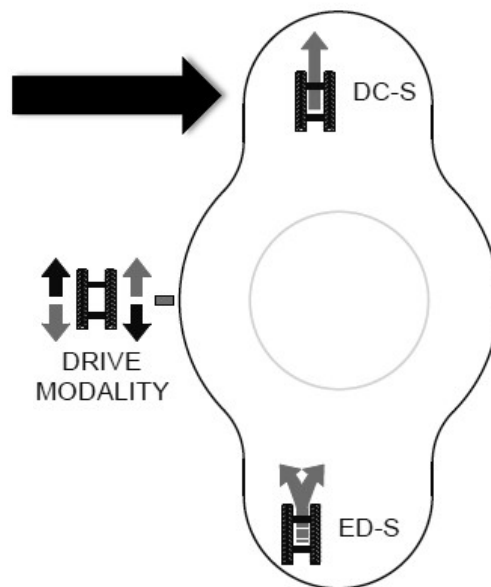

- 2) **Removing the pushbutton panel from the base and driving the platform on the ground:** with the platform in the transport position, the operator can move the machine directly from the ground using the portable pushbutton panel and following the instructions in PAR. 4.3 - DRIVING FROM THE GROUND WITH THE MOBILE PUSHBUTTON PANEL (see photo below).



- 3) **Lifting the platform** using a CE certified beam (not included) that should have a vertical distance of 350 mm between the hook and chain and, using hooks and steel ropes hooked to the holes marked with signs (see photo below). The ropes must possess safety factor 5.

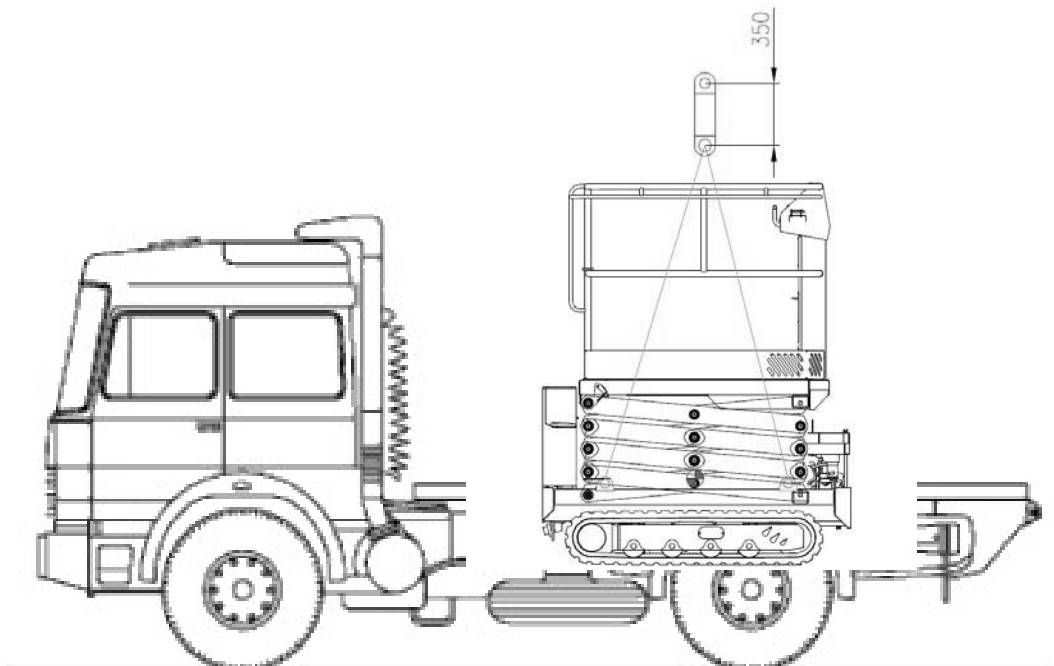

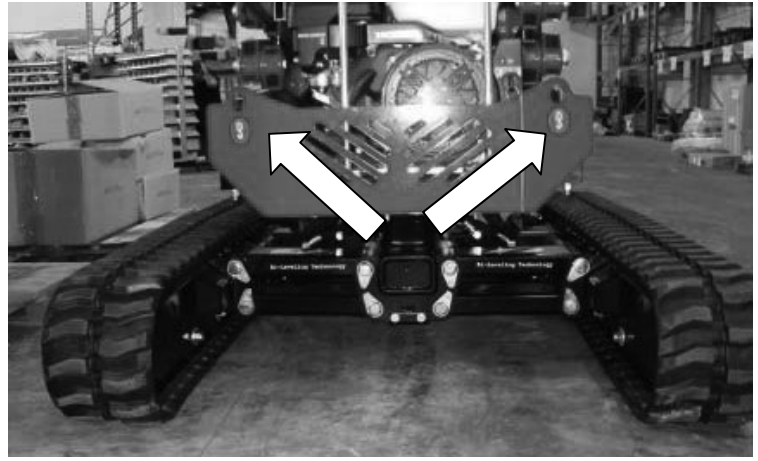
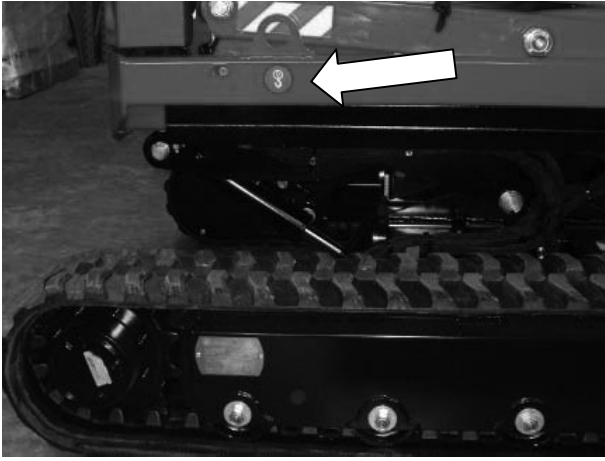

Note: Once the machine has been loaded onto the vehicle, it must be fastened in place by means of the holes used for lifting

Note: Make sure that the platform is FULLY LOWERED before transporting the machine.

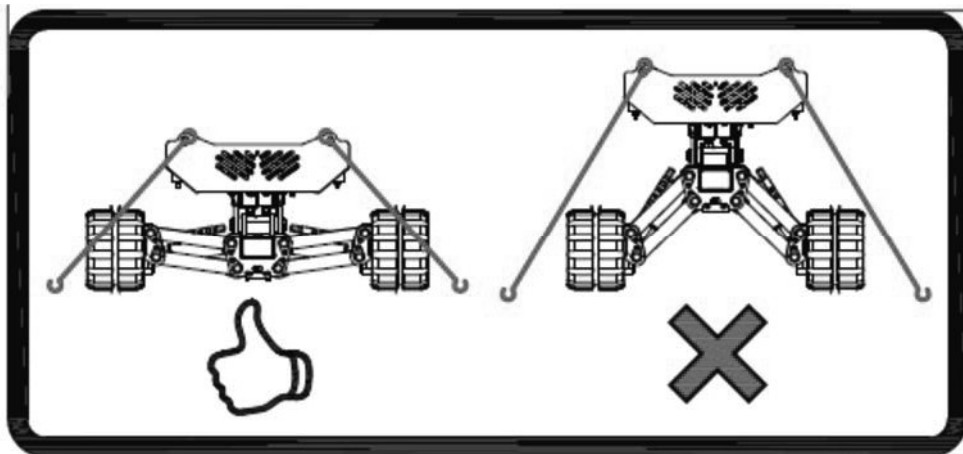

2.6 Inspections before use

- Make sure movements are done on flat, sturdy ground. This can be done using the inclinometer installed in the basket (see photo below).

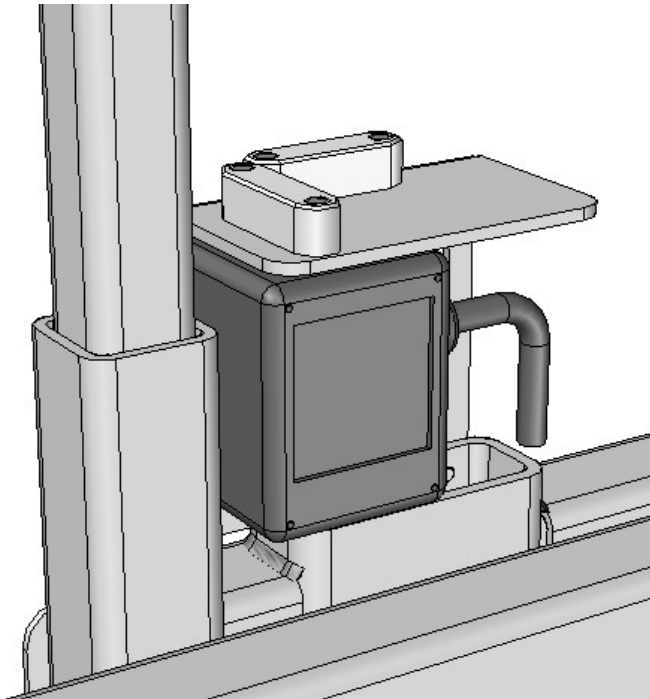

Basket inclinometer

- Make sure that there are no hollows or ridges in the floor and that there is enough room for the machine to pass through.
- Make sure that there are no bystanders or obstructions in the surrounding area before moving off.
- Visually check under and around the machine to make sure that there are no oil or gasoline leaks. If leaks are discovered, comply with the MAINTENANCE instructions.
- Check the fuel level before starting to work (see par. 6-5.-Refueling), thus preventing interruptions during work.
- Check the motor oil and hydraulic oil level (see par. 6.2.13-Checking and changing oil).
- Do not run the engine in closed areas like garages or the like. The engine exhaust gas contains carbon monoxide, a poisonous gas that can quickly saturate a closed space and cause difficulties or even death.
- Visually check to make sure that all screws, bolts, plug ring nuts are tight and that the welds are undamaged (see chap.6—Maintenance)
- Always check to make sure that track tension is correct

2.7 Inspections during use

- ***It is forbidden*** to use ladders or other structures in the basket to increase the height of the machine.
- ***It is forbidden*** to work near high voltage overhead electric power lines. Moreover, the basket must always keep at a safety distance of at least **5 meters** from cables.

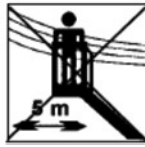

- ***Do not use the machine during storms.*** You could be struck by lightning.
- ***Use the MEWP only*** within the allowed temperature range (see Performance)
- ***It is forbidden*** to get on or off the MEWP when the platform is raised
- ***It is forbidden to load or unload objects from the MEWP when the platform is raised.***
- The carrying capacity of the MEWP is the work load for which the platform has been designed and includes the weight of the operators and the tools used for their specific tasks (see relative data plate)
- Do not CHANGE DIRECTION on kerbs, rocks or appreciable differences in level (> 20 cm) when driving the machine. In this case, always proceed perpendicularly to the obstacles.

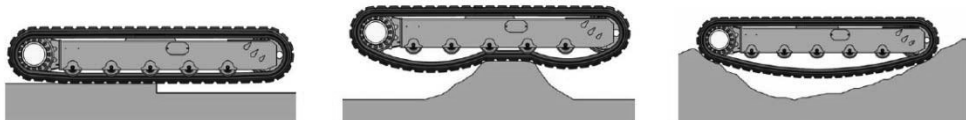

- If you must drive up a slope, do not change direction when the ground changes from flat to sloping. If this is absolutely necessary, perform the manoeuvre gradually.

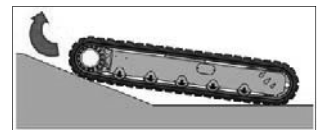

- Do not drive along the edge of slopes or over uneven ground with one track horizontal and the other slanting or partially raised (>10°) as this will damage the tracks. ALWAYS PROCEED WITH THE TRACK SHOES RESTING ON THE SAME HORIZONTAL PLANE.

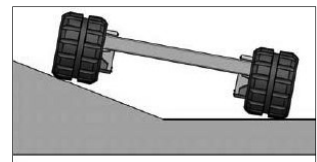

- Driving over an obstacle creates a gap between the bearing rollers and track, which could consequently slip out of its housing.

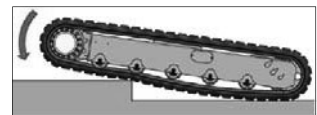

- If you change direction in a situation where the track could move sideways owing to an obstruction, the track could slip out of its housing.

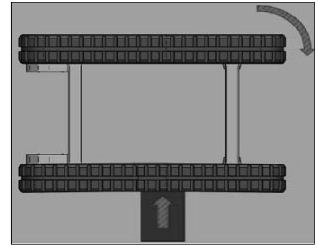

- Check to make sure that there are no bystanders near moving parts when the platform is lowered.



Attention: for inclined floors, pay attention to the correct LEVELLING direction. **Avoid inclining the platform beyond what is necessary towards the lower side of the platform!**

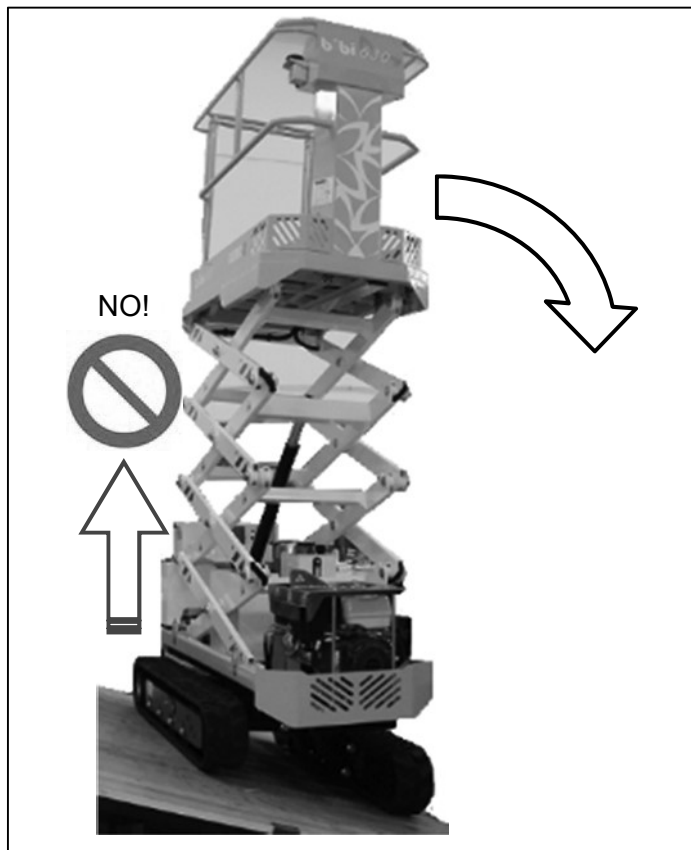

- Avoid smooth, slippery and/or icy and sandy surfaces: during levelling these could cause slipping or tipping.

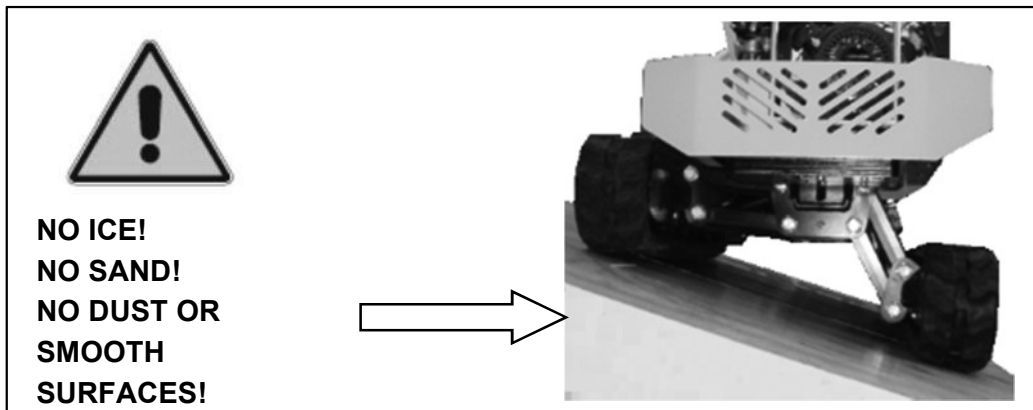

Attention: during movement with ELECTRICAL POWER be careful of the connection cable in order to avoid dangerously crushing personnel on the ground!

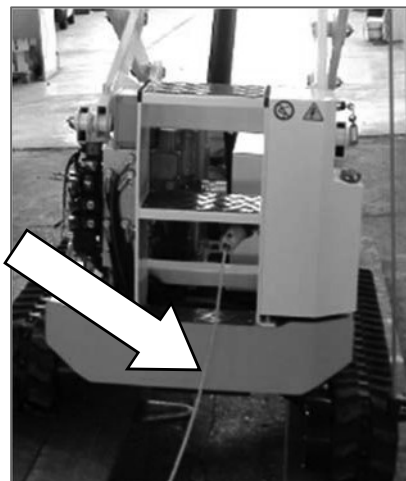

Note: The platform has an "anti-crushing" system (ref. Point 5.4.4 EN 280), which activates when the platform lowers and temporarily blocks it to allow the operator to make sure that there are no bystanders in the vicinity.

2.8 Precautions when work terminates or is interrupted

- *It is forbidden* to leave the MEWP unattended without having first stopped the engine and removed the keys from the control panel to prevent the machine from being used by unauthorized persons

2.9 Safety regulations during maintenance



The maintenance operations described in this Manual refer to platforms in conditions of normal use. In heavy duty use conditions (e.g. extreme temperatures, dust and corrosive substances in the environment, etc...), inform the ALMAC S.r.l. assistance services to have the maintenance intervals checked and changed.

The MAINTENANCE operations must only be performed by authorized and adequately trained personnel.

Only perform the MAINTENANCE and ADJUSTMENT operations described in this Manual. Contact the ALMAC S.r.l. assistance service only, if other operations are required (e.g. if faults occur).

All MAINTENANCE work must be performed in compliance with the laws in force governing safety and protection of the environment.

THE MANUFACTURER IS RELIEVED FROM ALL LIABILITY FOR ACCIDENTS OR FAULTS DUE TO FAILURE TO COMPLY WITH THE RECOMMENDATIONS AND SAFETY REGULATIONS.

- Maintenance must only be carried out after the emergency push-button has been pressed and the engine turned off.
- Before proceeding with the interventions, make sure the platform is completely blocked.
- If the basket must be raised for maintenance purposes, the platform and lifting structure must be prevented from accidentally lowering. To do this, there is a device on the lift arm that must be set in a precise position so as to immobilize the scissor structure (*see procedure described below*).

- **Take care of the environment:** avoid spilling oil when changing it or topping up. Used oil must be disposed of in accordance with the laws in force.



- **Never insert the body, limbs or fingers in sharp, jointed opening on the machine that is not controlled or without proper guards unless securely blocked.**



- Never use petrol, solvents or other flammable liquids as detergents: use the authorized, non-flammable, non-toxic solvents available from the market.



- Do not use open flames for lighting purposes when performing maintenance.

- Make sure that there are no fluids under pressure before disassembling unions or pipes: Immediately call a physician if injuries occur or the fluid from pipes is accidentally ingested. Remember that fluid seeping from a very tiny hole can be



almost invisible but possess sufficient force to penetrate under the skin. Use a piece of card or wood to check for leaks.

- **Make sure that all parts of the hydraulic circuit have been tightened correctly.**
- When compressed air is used for cleaning parts, protect yourself by wearing goggles with side guards and limit the pressure to 2 atm maximum (1.9 bars)



EXTENSIBLE STRUCTURE LOCKING SYSTEM

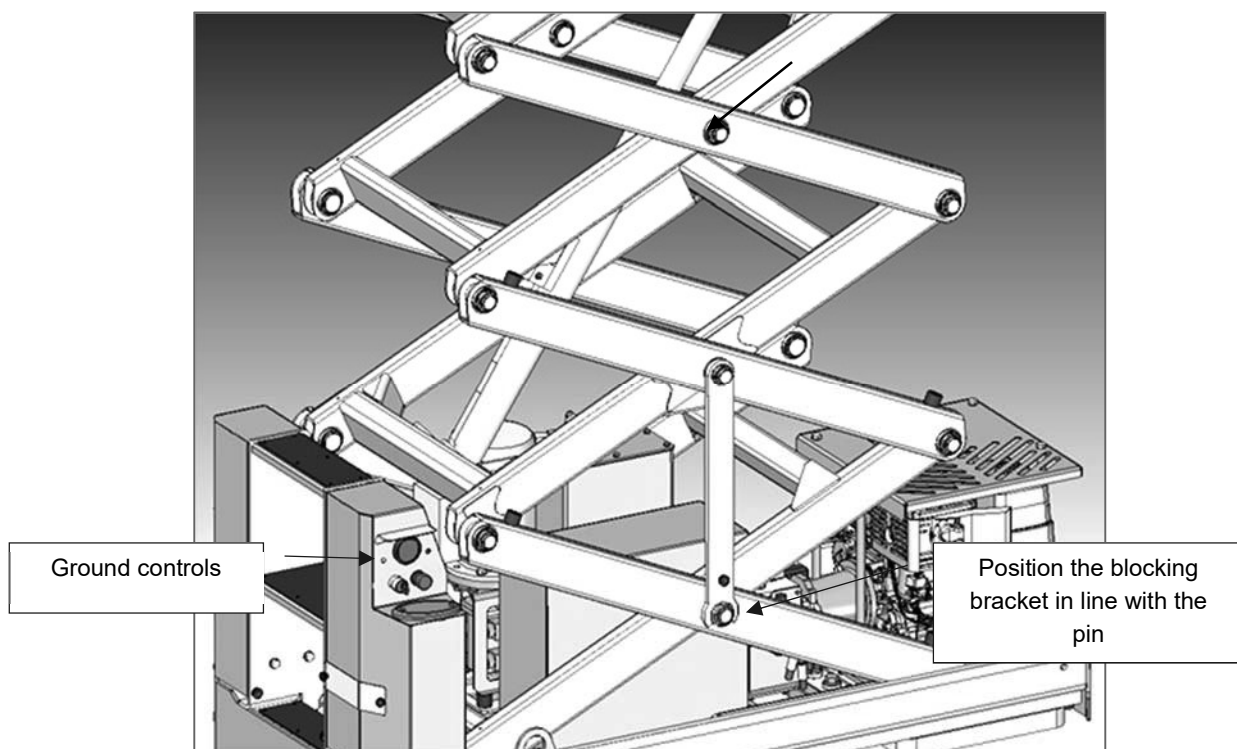

The photo above shows how the locking system of the extensible structure must be positioned during maintenance work. Using the "ground controls" (*see par 4.4 Use of ground controls*) you can lift the basket until you can position the blocking bracket in a vertical position and aligned with the pin below. The basket must be lowered slowly until the bracket is not blocked in the respective pin.

2.10 Personal Protective Equipment (PPE)

For safe use of the machine, use the appropriate personal protective equipment that must be worn before entering the basket and used as indicated.

- Holding device
- Hard hat
- Safety shoes
- Protective gloves

HOLDING DEVICE

Before entering the basket a suitable protection against falls must be worn. The system must completely prevent falls from heights.

The safety device consists of a full body harness (1) according to UNI EN 361, with chest and/or back attachment and retaining rope (2) or adjustable positioning (EN 358) to prevent the fall, hooked to the attachment point in the basket using connectors (3) (EN 362) of suitable shape and size.

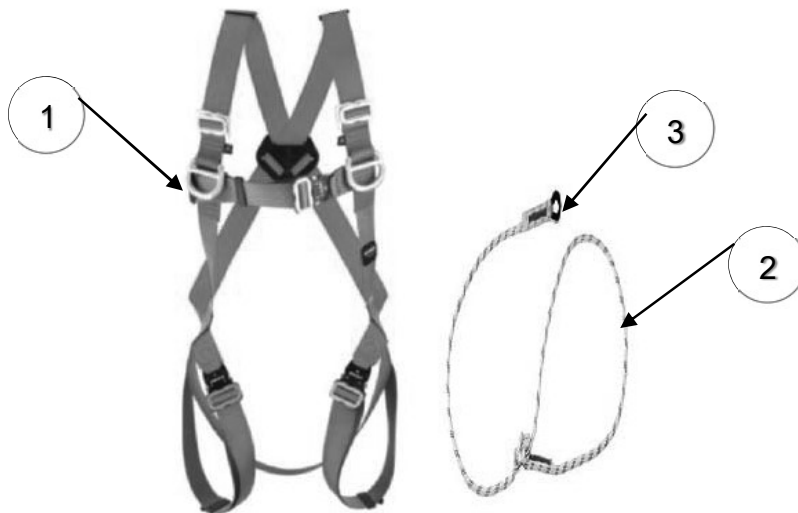

Once in the basket, attach the connector to one of the attachments on the floor in the front part of the platform and indicated by a symbol. Then adjust the rope so that it is as short as possible in order to hold the operator inside the basket.



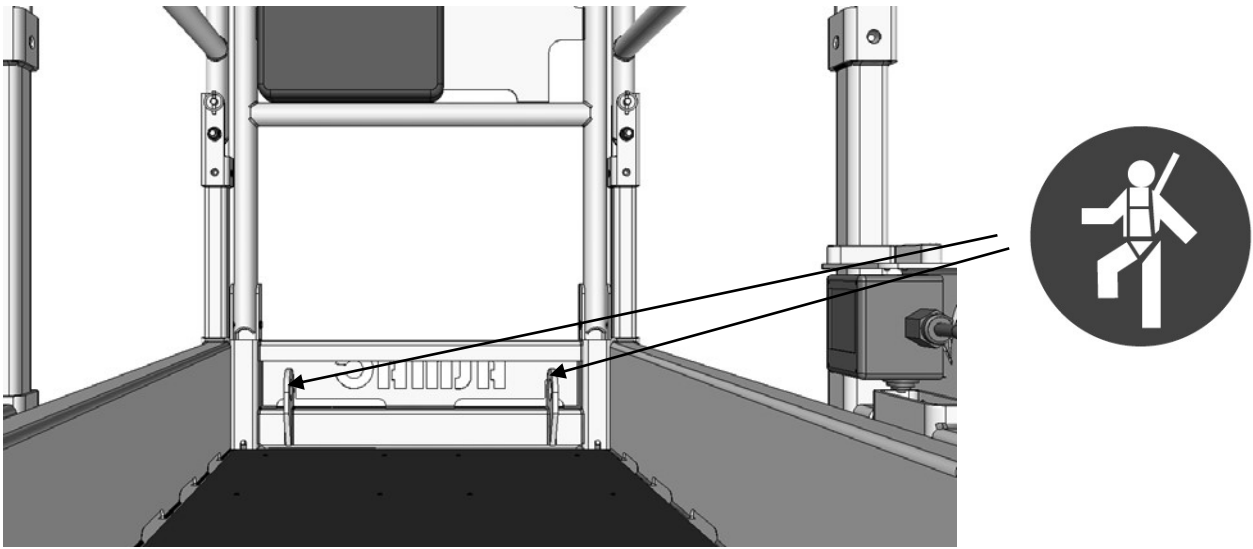

Basket attachment points



Attention: This device is not intended as an anti-fall device but to prevent a fall.

PERSONAL PROTECTIVE EQUIPMENT

<p>Body protection required</p>	<p>Protective gloves required</p>	<p>Safety shoes required</p>	<p>Hearing protection required</p>

Machine Description

3.1 Structure of the machine

This section describes the main components of the machine and their functions.

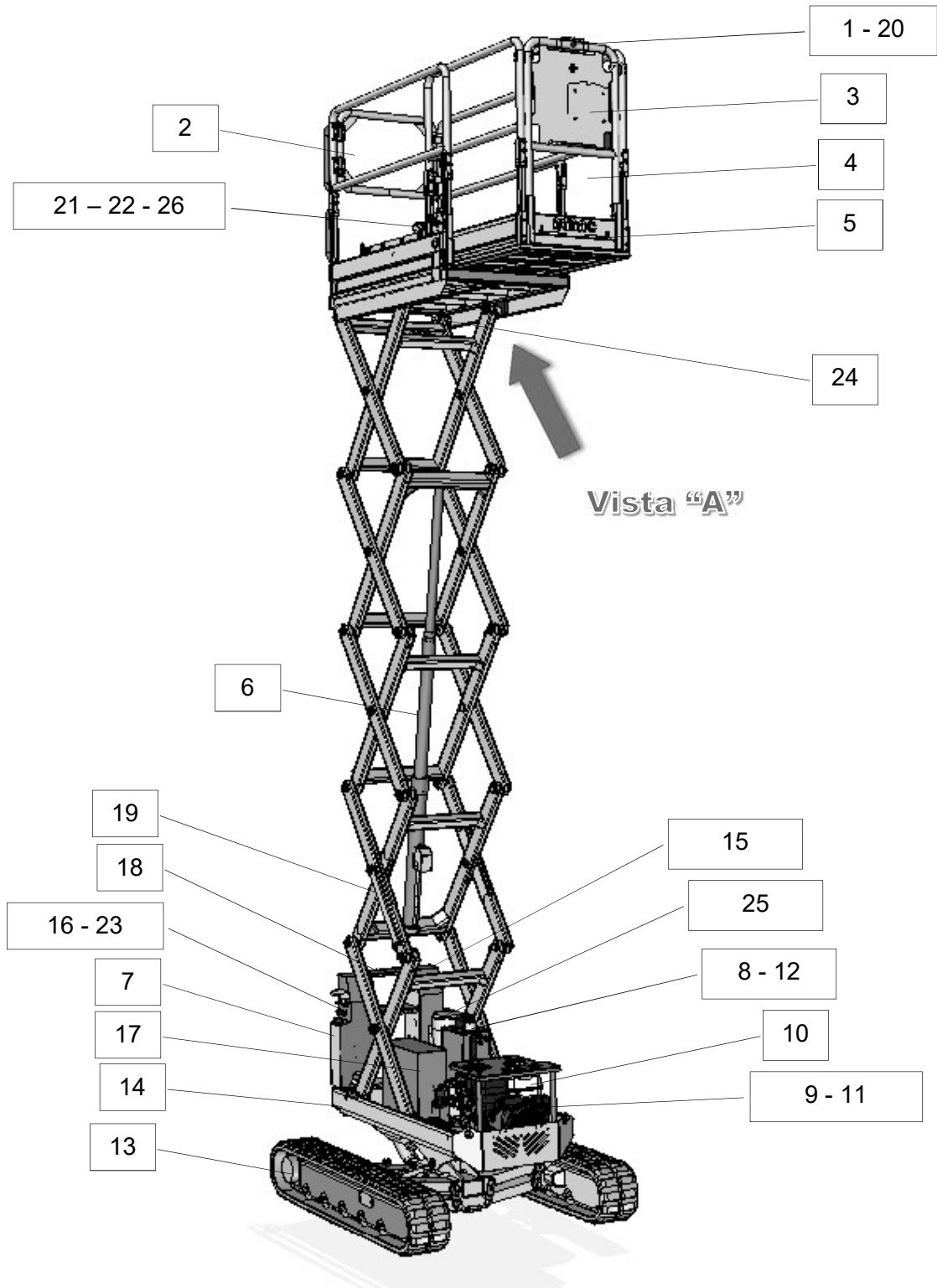

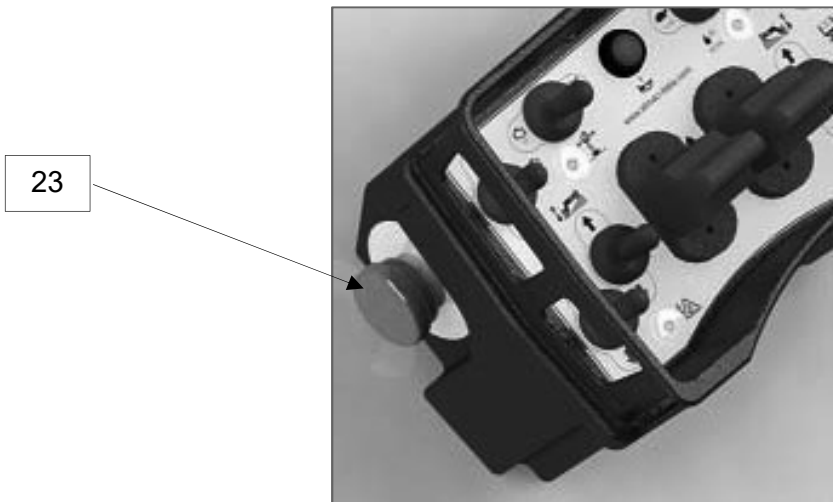
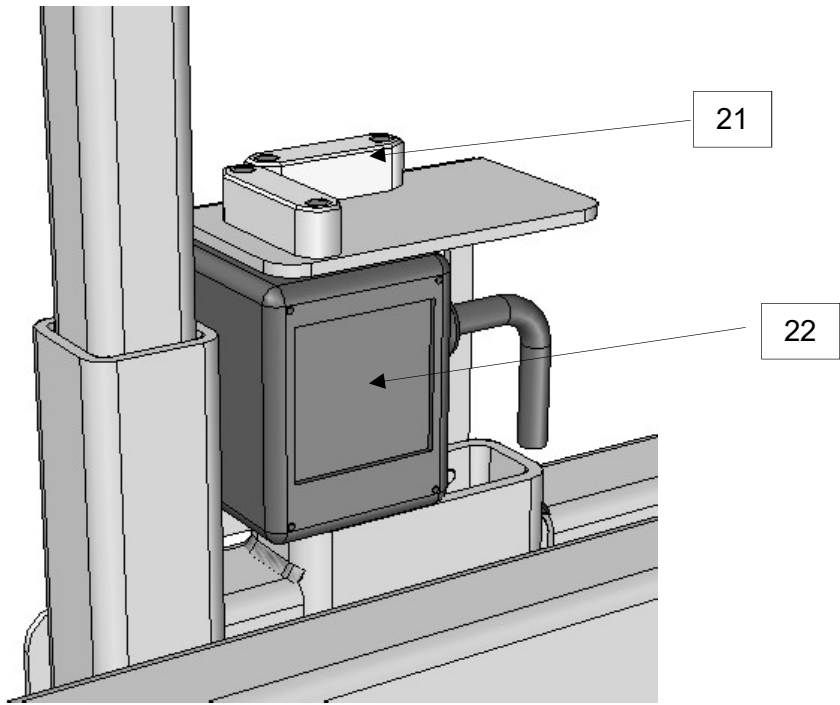
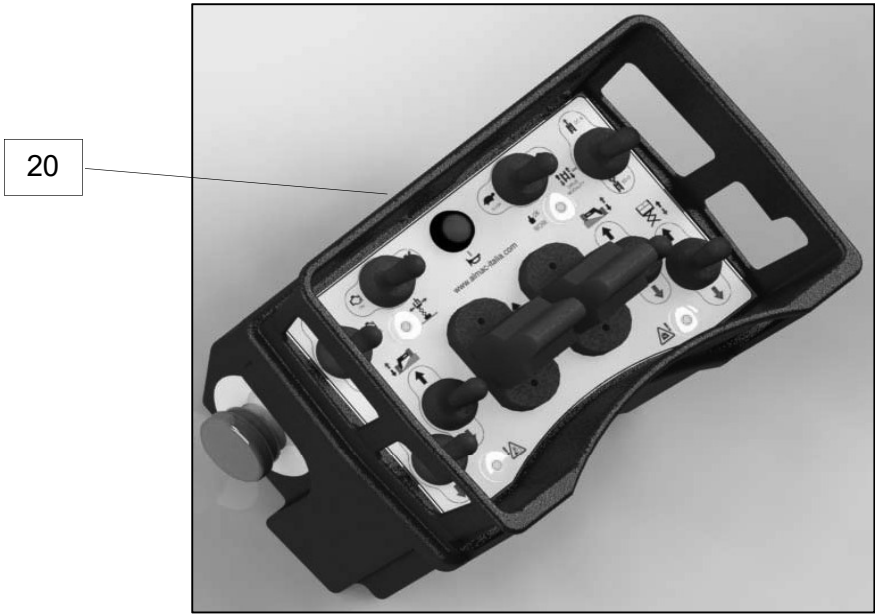



24

View "A"



12

25

8



16

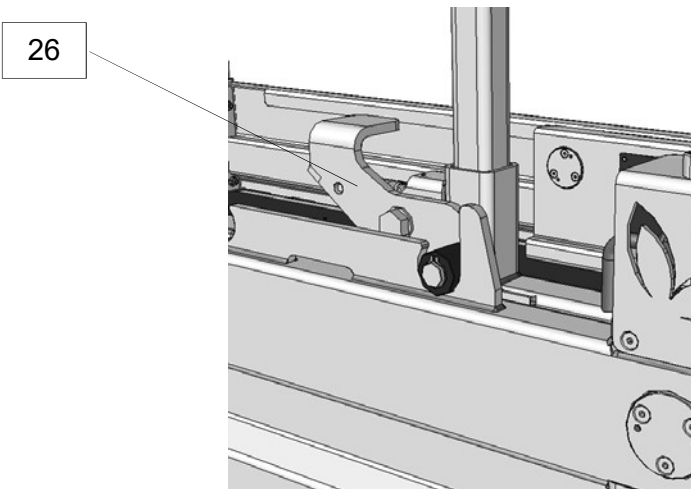
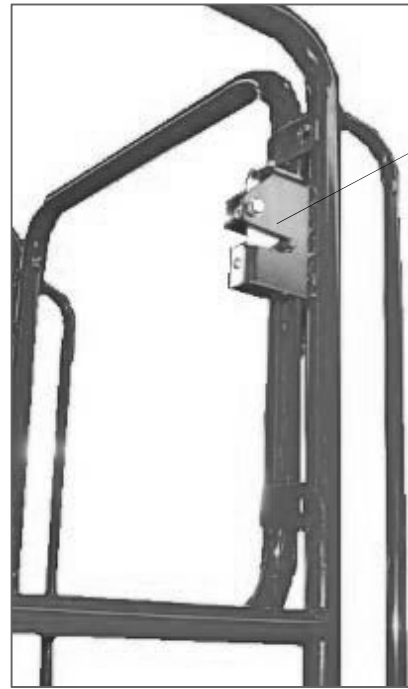
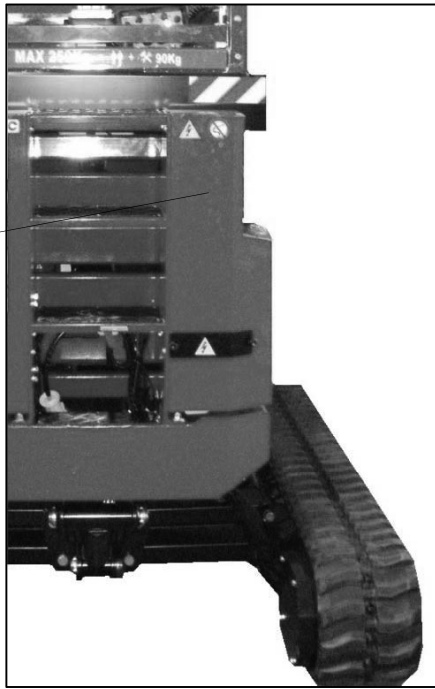

3.1.1 Main parts of the machine

- 1 – Console and handgrip
- 2 – Opening device for access
- 3 – Storage compartment
- 4 - Extensible basket
- 5 – Extensible structure
- 6 – Hydraulic lift cylinder
- 7 – Electrical panel
- 8 – Hydraulic circuit filters
- 9 – Hydraulic pumps
- 10 – Fuel tank
- 11 – Combustion engine
- 12 – Hydraulic oil tank
- 13 - Crawler with side and length levelling (bi-levelling)
- 14 – Platform frame
- 15 – Hydraulic valve housing
- 16 - "Emergency lower" control
- 17 – Electrical enclosure
- 18 – Ladder
- 19 – Locking bar for maintenance
- 20 – Control panel
- 21 – Inclinator
- 22 - 220v socket
- 23 - Emergency push-button
- 24 – Safety inclinometer
- 25 - 220V ac electric motor
- 26 - Basket extension device

3.2 Operator interface

3.2.1 Pushbutton panel lights and controls



Symbol	Identification	Function
1	Indicator light	Planarity alarm:
		OFF= lateral inclination 0°-1°
		Longitudinal inclination 0°-1°
		ON= lateral inclination >1°
2	Indicator light	Traction enabling
		OFF= traction not enabled ON=traction enabled
3	Indicator light	Work enabling
		OFF= platform not levelled
		FLASHING= platform levelled/movement at height not permitted
		ON= platform level/ movement allowed up to 4.4 m walking surface
4	Indicator light	Overload alarm
5	Return lever	Starting/stopping the electric or internal combustion engine
6	3P Switch	ENGINE position =Standard operation-no line 220V in basket (with combustion engine running)
		ELECTRIC ENGINE position =switching off the combustion engine and enabling the electric motor startup with button-7; activation line 220V at the socket in the basket
		OUT 220 position = standard operation-internal combustion engine active - 220V line in basket active (from inverter)
7	Button	Warning buzzer
8	3P Switch	CENTRAL position = standard operation - traction FORWARD/REVERSE enabled using 2 joysticks
		DC-S position= Simultaneous movement FORWARD/REVERSE of both tracks with one single joystick (11)
		ED-S position = Easy Drive System assisted drive control system
9	2P Switch	Tortoise position= low speed for all movements Hare position= high speed for all movements
10	Joystick	Left track FORWARD/REVERSE movement control
11	Joystick	Right track FORWARD/REVERSE movement control
12	Return lever	Left platform levelling UP/DOWN
13	Return lever	Right platform levelling UP/DOWN
14	Return lever	Manual length levelling UP/DOWN
15	Return lever	Raise / lower basket with automatic levelling
16	Mushroom button	EMERGENCY STOP

3.2.2 Ground controls



Symbol	Identification	Function
17	3P Key switch	LEFT position = electrical panel on - mobile pushbutton panel disabled - ground controls enabled
		CENTRAL position= platform off
		RIGHT position = electrical panel on - ground controls disabled - mobile pushbutton panel enabled
18	Button	Platform emergency button
19	Return lever	Basket ascent/descent
20	Return lever	Starting/stopping the electric or internal combustion engine
21	Measurer	Electronic hour-counter (with combustion engine running)



Attention: only personnel who have been properly trained and skilled in using the controls may use those controls.

IT IS FORBIDDEN to stay inside the basket while another operator performs manoeuvres with the ground controls.

3.3 Safety devices



Attention: Periodically verify that the safety devices are operating correctly. During work, the operator must be able to assess, recognize and avoid all dangers and must immediately inform the persons in charge of any faults in the safety devices so that they can be inspected and restored to their original conditions of safety and reliability.

The platform comprises a complete set of safety devices.

3.3.1 Chassis inclination monitoring device

On the machine is installed a device that control the inclination of the main frame.

The device is placed at the bottom of a casing placed inside the scissors

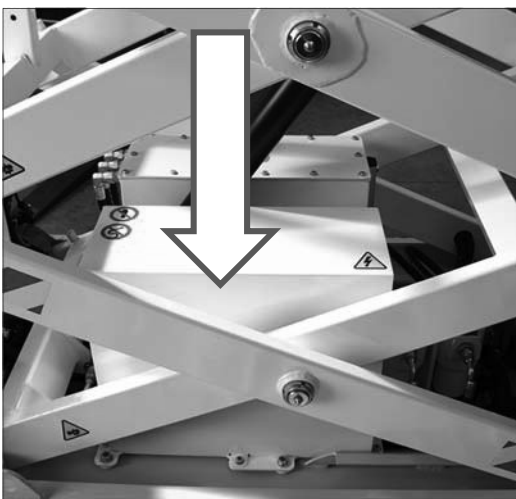

This is controlled by a modern electronic control unit that works **along with the track width control device** (safety limit switch on track levelling) to basket ascent if permitted maximum inclination is exceeded, thereby avoiding unstable positions.

If the maximum inclination height is reached a warning buzzer sounds and the indicator lights on the console is lit:

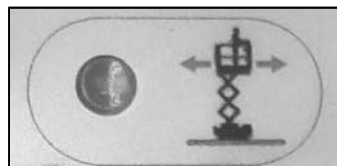
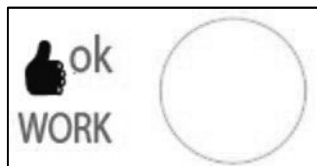

The device signals can vary as follows

Signal	
"OK WORK" LIGHT - OFF "TRANSLATION" LIGHT - OFF	- Machine not leveled - Translation not allowed - Raising not allowed
"OK WORK" LIGHT - ON "TRANSLATION" LIGHT - OFF	- Machine leveled - Raising allowed - Translation not allowed
"OK WORK" LIGHT - ON "TRANSLATION" LIGHT - FLASHING	- Machine leveled - Raising allowed - Translation allowed (up to max 5m working height)
"OK WORK" LIGHT - ON "TRANSLATION" LIGHT - ON	- Machine leveled - Raising allowed - Translation allowed (up to max 6m working height)

3.3.2 Work platform elevation monitoring device

On the upper beam of the scissor, just under the work platform, is positioned an angle sensor.

The difference of angles values between this angle sensor and the chassis angle sensor is constantly monitored.

The machine automatically deduces the elevation of the work platform by monitoring this difference



3.3.3 Lifted load limiting device

The machine has a work platform, that when extended, is greater than 1 m² of surface, therefore, on the cylinder are installed two pressure transducers that prevent the lifting of the platform from the recovery position, in case of exceeding by more than 20% of the load.

If an overload condition is sensed at or above this height, further elevation is prevented.

All normal movement of the work platform is prevented.

Normal movement can only restart if the overload is removed.

In this situation the warning lights (n°4 shown below) is Flashing and an intermittent beep will be heard until you remove the excess load.



WARNING:

- NEVER exceed the machine's established maximum capacity.
- THE OPERATOR IS PROHIBITED TO MOVE BETWEEN THE BASKET AND A STRUCTURE OUTSIDE THE MACHINE, MACHINE STABILITY COULD BE JEOPARDISED. PERSONNEL AND THE EQUIPMENT MUST ENTER AND EXIT THE CAGE ONLY WITH THE SCISSOR IN STOWED POSITION AND BASKET RETRACTED.

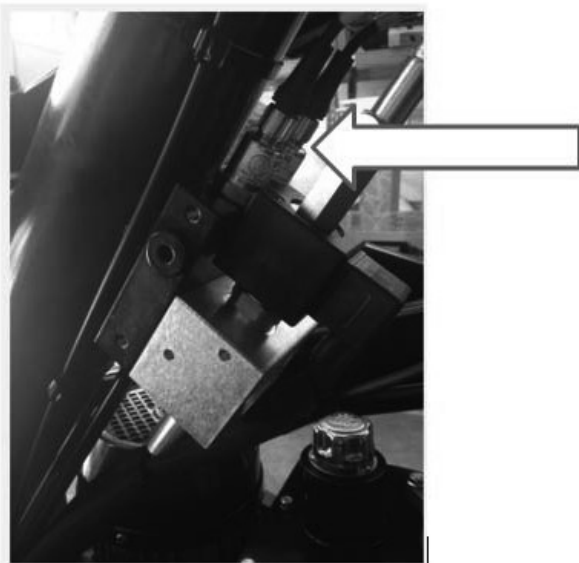

3.3.4 Hydraulic pressure limiting devices

The platform's hydraulic circuit is equipped with **pressure relief valves** (1) to limit the force exercised in the hydraulic gearmotors of the tracks and track chassis expanding cylinders, thereby protecting them from damage.

These valves need no adjustments since they are calibrated by ALMAC S.r.l. when the machine is tested. The diagram below illustrates the integrated power pack and the position of the pressure relief valves described above.

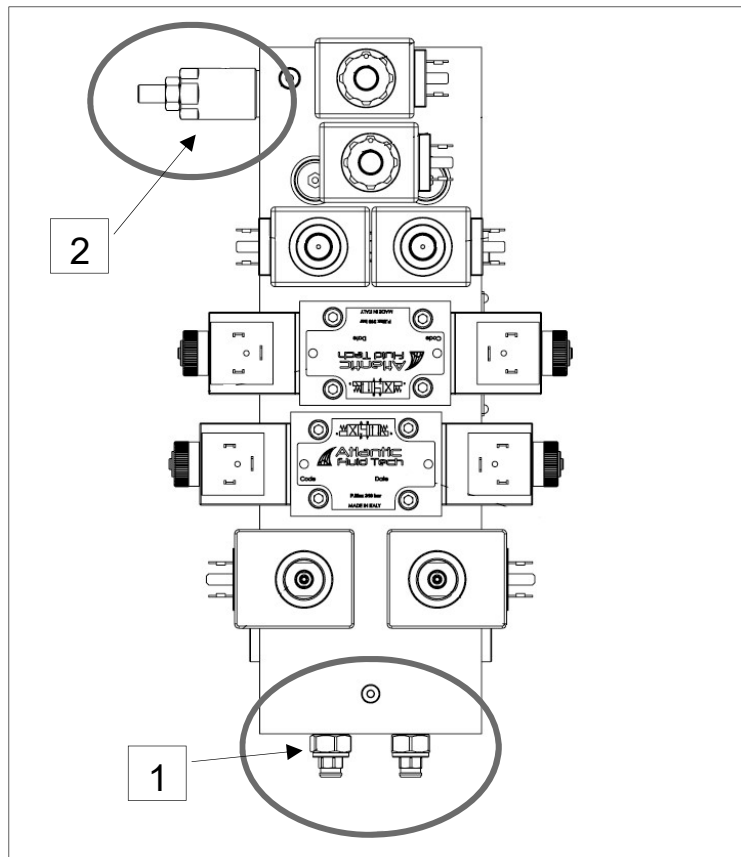

The integrated hydraulic power pack also includes a **pressure relief valve for the lifting circuit** (2). This provides additional safety, besides the overload monitoring device installed, to prevent the machine from becoming unstable and tipping over.



Attention: modifications to the positions of the pressure relief valves without authorization from ALMAC S.r.l. will void the warranty and any claims made by the customer.

3.3.5 Power (electric) cut-out devices

The basket can be fitted with a 220 V power socket to supply the power tools required during work. For safety reasons, a device is installed so as to cut-out the electricity supply in case of over-voltage or short-circuit (2), located inside the right rear casing (pos. 1 in the photo below). To access the device, unscrew the knobs (3) on the casing and remove the guard. When finished, replace the guard that was previously removed and thoroughly tighten the knobs.

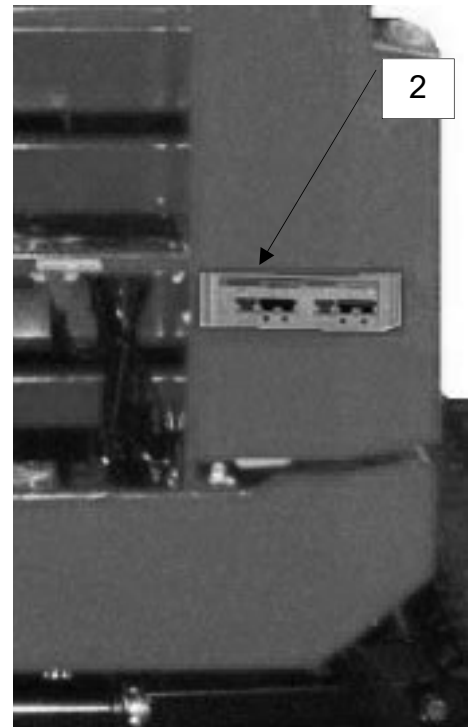
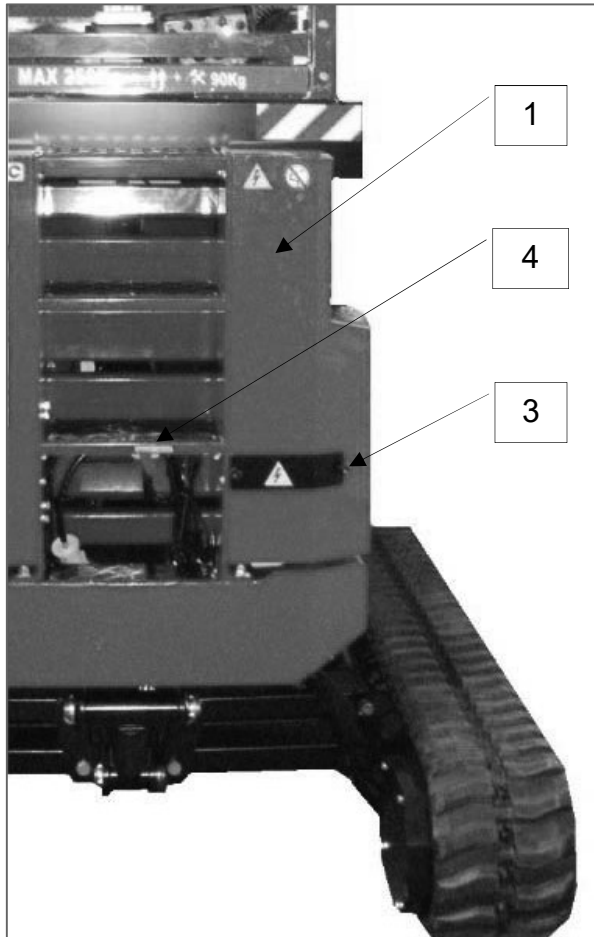

The battery isolator (4) is located in the same position. It physically disconnects the 12v electric line coming from the battery and supplies the various users.

BE SURE TO OPERATE THIS DEVICE AT THE END OF THE WORK DAY.

Near the access ladder (see Figure "A") and life-saving devices (figure "B") there are also security fuses to protect the 12V electrical equipment.

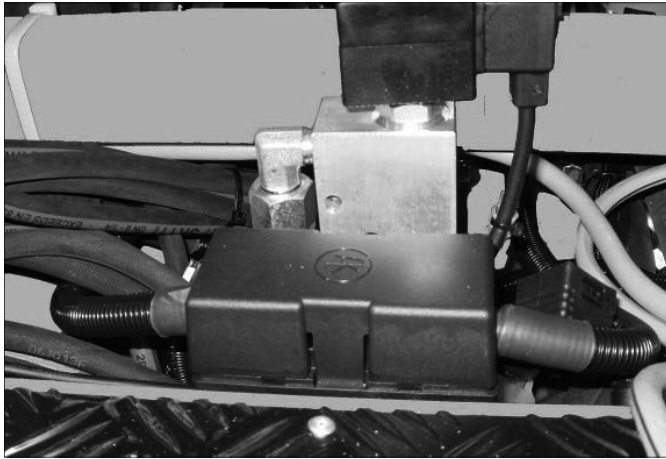
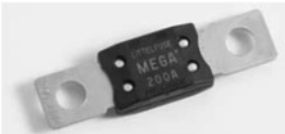

Figure "A"

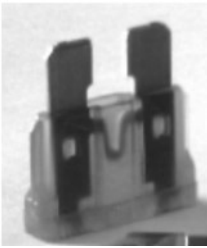

Figure "B"

The fuse features are as follows:



150 amperes (megafuse)



15 amperes (F1) / 10 amperes (F2)

3.3.6 Hydraulic failure safety devices

If there is an accidental failure in the hydraulic piping that supplies the **basket lifting circuit**, the lifting circuit hydraulic system has the following safety devices (ref. Point 5.10.2 UNI EN280:2013):

- RIGID PIPING appropriately sized connecting with the safety valve block
- An electric PILOT VALVE connected directly to the cylinder to prevent uncontrolled descent of the basket from any height, thus avoiding dangerous situations. This valve also has a ROPE EMERGENCY CONTROL in the event of an emergency.

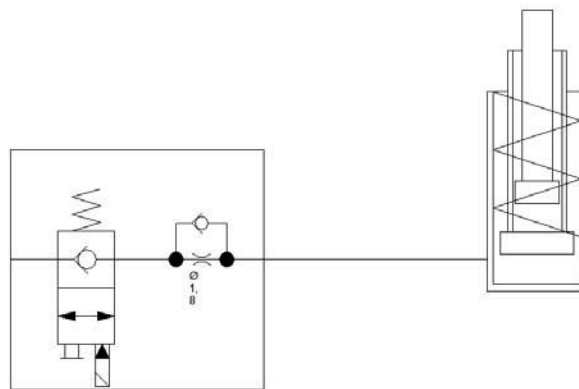

- A COMPENSATING VALVE that limits the basket descent in the event the rigid supply pipe is broken. The device is always functioning during normal machine operation.
- ! Proceed as described below to restore the machine to normal operating conditions:
1. repair the damaged hydraulic hose and/or connections

2. fill and bleed the hydraulic circuit
3. lift the platform to the maximum height

If the hydraulic hoses that supply the **track chassis levelling cylinders** function in a faulty way and suddenly change the track, dedicated PILOT-OPERATED CHECK VALVES prevent the track from changing back (ref. Point 5.10.2 EN280).

- ! To restore the machine to its normal operating conditions, repair the damaged hose/hoses and restart the system

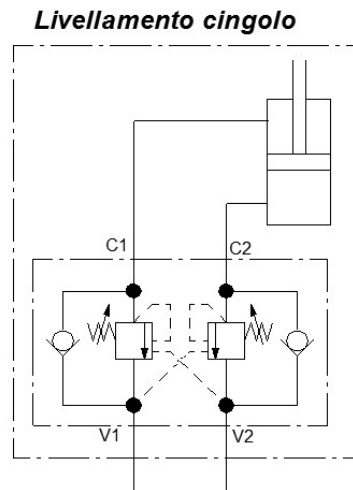

Hydraulic diagram of pilot-operated check valves

4.1 Preliminary operations

4.1.1 Ground fitness for permitted inclination

To assess whether the ground is fit to bear the machine, it is extremely important to ensure that the ground surface does not allow the machine to slip once it has been stopped for work.

Two factors contribute towards increasing the danger of slipping:

- a) Slope
- b) Poor grip (or slipperiness) due to a low friction coefficient

These two factors must be assessed with the utmost care, and at the same time as each other. There are no acceptable values for one "factor" that can exclude the risk of slipping if the other factor is extremely unfavourable. Ground that is almost flat may not be fit if its surface is icy. On the other hand, a surface with high adhesion may not be fit if it slopes too steeply.

Flat, horizontal ground is the ideal surface for work platform stability, even though this condition is very rare.



- Avoid smooth, slippery and/or icy and sandy surfaces: during levelling these could cause slipping or tipping.

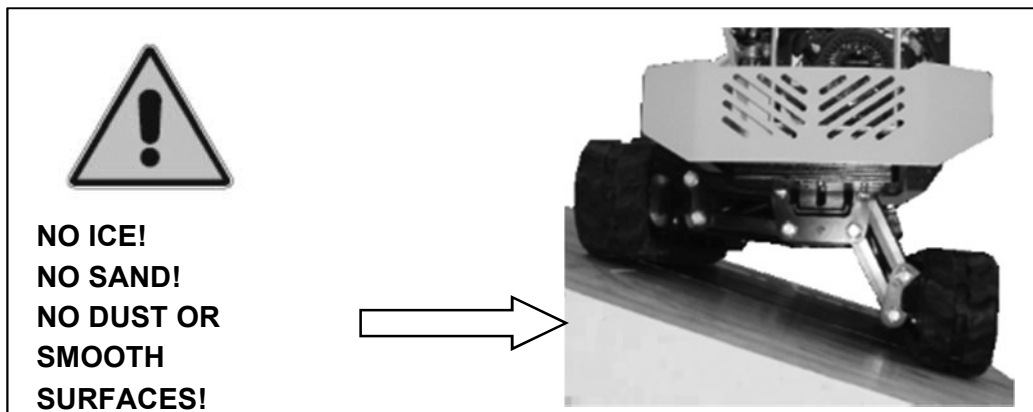

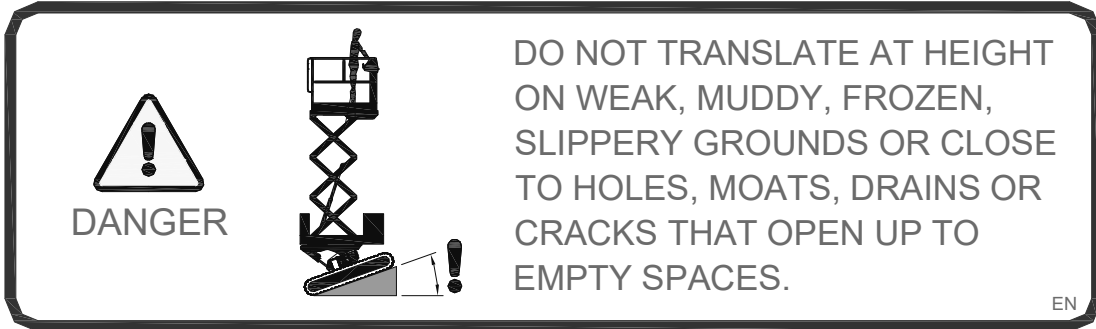

A warning sign with a black border and rounded corners. On the left is a triangle with an exclamation mark and the word "DANGER" below it. In the center is an illustration of a scissor lift on a sloped, uneven surface with a small hole and a warning icon. On the right is the text: "DO NOT TRANSLATE AT HEIGHT ON WEAK, MUDDY, FROZEN, SLIPPERY GROUNDS OR CLOSE TO HOLES, MOATS, DRAINS OR CRACKS THAT OPEN UP TO EMPTY SPACES." The letters "EN" are in the bottom right corner.

DANGER

DO NOT TRANSLATE AT HEIGHT ON WEAK, MUDDY, FROZEN, SLIPPERY GROUNDS OR CLOSE TO HOLES, MOATS, DRAINS OR CRACKS THAT OPEN UP TO EMPTY SPACES.

EN



Note: Do not use the MEWP if you are doubtful about the fitness of the ground surface.

4.1.2 Action of the wind

It is forbidden to use the machine if the wind speed exceeds 12.5 m/s.

The following chart describes the consequences of different wind speeds (Beaufort scale).

Scale of the Italian Hydrographic Service			Beaufort International Scale				Effects
N°	Wind description	Speed in km/h	N°	Wind description	Corresponding speed		
					In km/h	In m/sec	
0	Calm	0-7	0	Perfect calm	1,08 3,60	0,3 1,0	Calm, smoke rises vertically
			1	Light air, bora	6,12 7,20	1,7 2,0	Wind direction shown by smoke but not by wind vanes
1	Light wind	7-14	2	Light breeze	11,16 14,40	3,1 4,0	Wind felt on face; leaves rustle; vane moved by wind
2	Moderate breeze	14-29	3	Light wind	17,28 21,60	4,8 6,0	Leaves and small twigs in constant motion. Wind extends flags.
			4	Moderate breeze	24,12 28,80	6,7 8,0	Wind raises dust and leaves. Branches are moved.
3	Almost strong breeze	29-36	5	Fresh breeze	31,68 36,00	8,8 10,0	Small bushes begin to sway. Waves form with white foam crests.
4	Strong breeze	36-50	6	Strong breeze	38,52 43,20	10,7 12,0	Large branches in motion.
			7	Near gale	46,44 50,40	12,9 14,0	Whole trees in motion.
5	Gale	50-83	8	Gale	55,44 61,20	15,4 17,0	Wind breaks branches off trees; difficulty in walking against the wind.
			9	Strong gale	64,80 72,00	18,0 20,0	Structural damage (chimney-pots and slates removed)
			10	Storm	75,60 82,80	21,0 23,0	Trees uprooted. Serious structural damage.
6	Hurricane	83-108	11	Violent storm	86,40 108,00	24,0 30,0	Widespread damage.
	Not classified		12	Hurricane	144,0 180,0	40,0 50,0	Countryside is devastated



Danger: The platform must never be used when wind speed corresponds to values 7 to 12 of the Beaufort scale. Work must be performed with the utmost attention with wind speeds between 4 and 6 of the scale.

4.1.3 Basket access

The basket must only be accessed with the platform completely LOWERED.

Climb into the command position using the ladder (see figure below) up to the last step.

Then, holding firmly onto the railing with one hand, use the "release lever" indicated in the figure below and manually open the access gate.

Once you have climbed into the basket, the bar will return to its initial position to protect you from falling from heights.

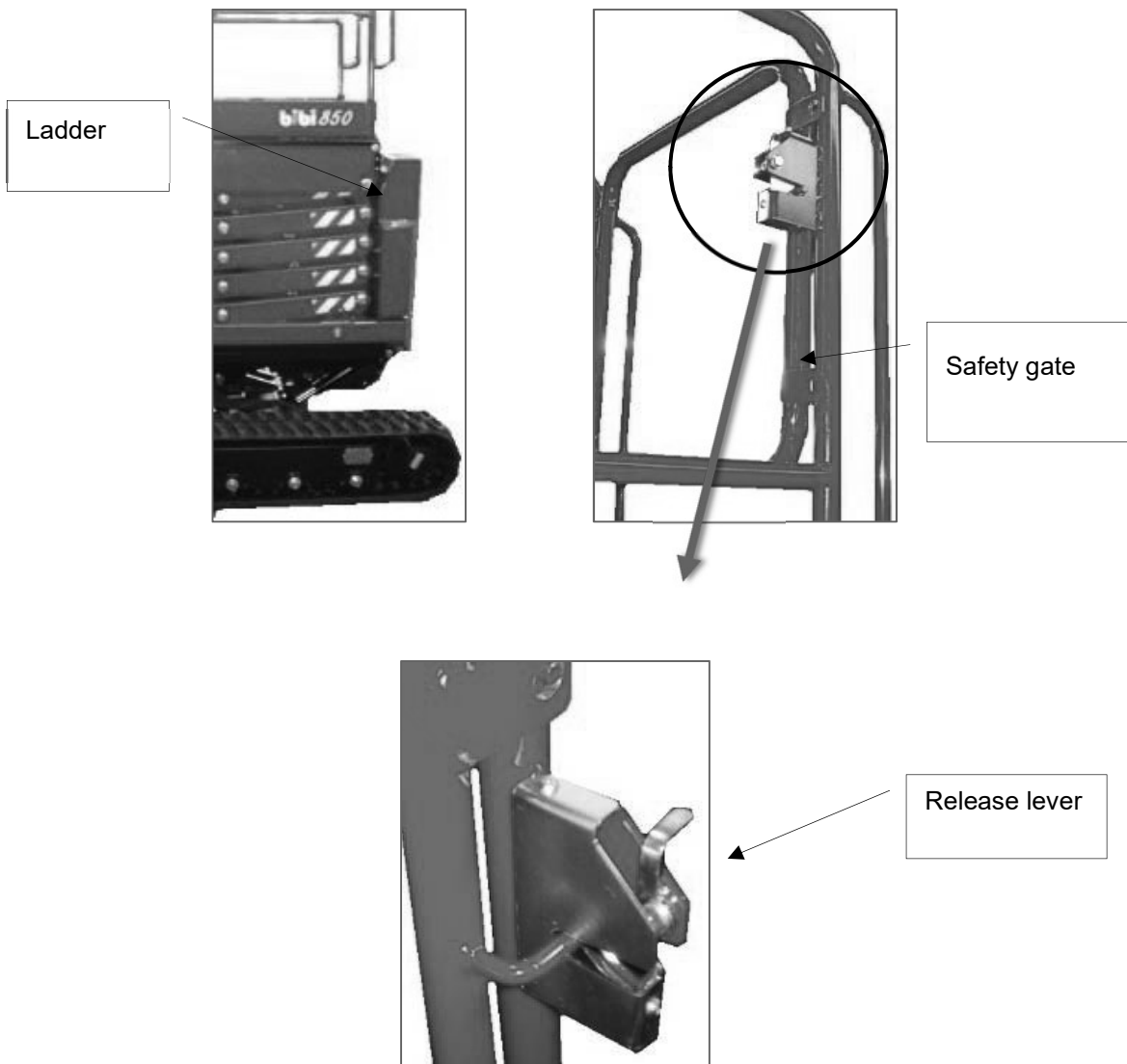

4.1.4 Expanding the basket

The basket of the ATHENA 850 platform is provided with a driven mechanism that enables to further extend the work area so as to reach more distant parts. To expand the basket:

1. Enable, using the feet, the "**unlocking pedal**" located at the base of the basket;
2. By using the feet force and keeping firmly one hand to the basket railing, extend it by applying force on the central part of the fixed base.
3. Once the basket is extended as much as necessary, release the pedal and lock the pin in the reference bore.
4. To shrink back the basket, carry out the same operations in reversed order.

The basket of the ATHENA 850 platform is provided with a driven mechanism that enables to further *expand* the work area so as to widen the work space and reach more distant parts.

To expand the working area, get in the basket and:

1. Push the unlocking pedal (**A**)
2. Push manually the basket floor by grasping it by the railings (**B**) over the minimum footprint.
3. Make sure the pin of the pedal is locked in one of the 5 available seats (**C**)

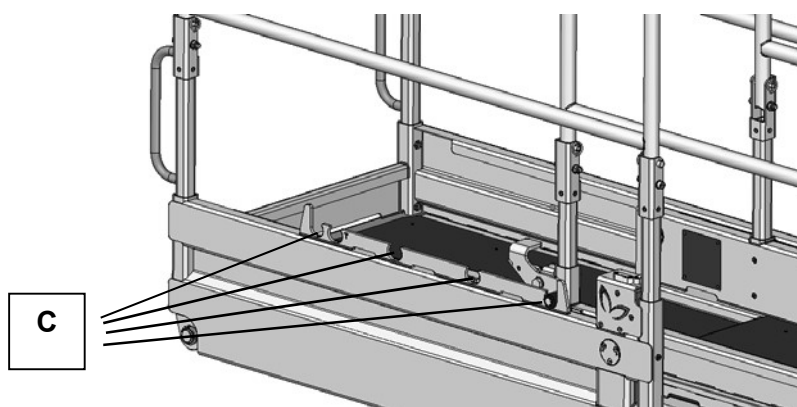
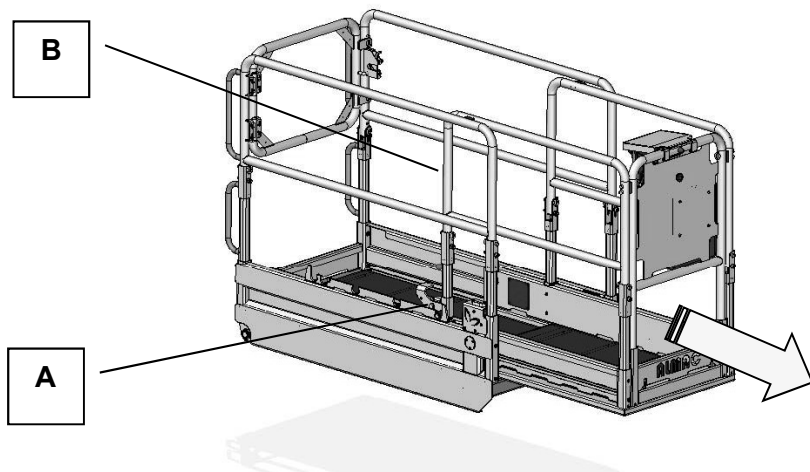



Warning: while descending from the working position, pay attention to possible obstacles beneath the basket to avoid tilting!

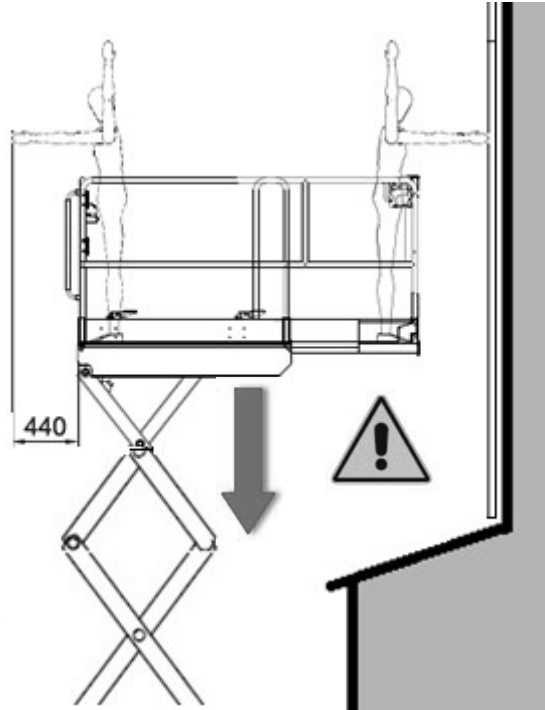

4.1.5 Combustion engine starting

To start the combustion engine and the hydraulic pumps, use the key on the ground controls (17). Before starting, perform the inspections described in sect. 2.6- *Inspections before use*.

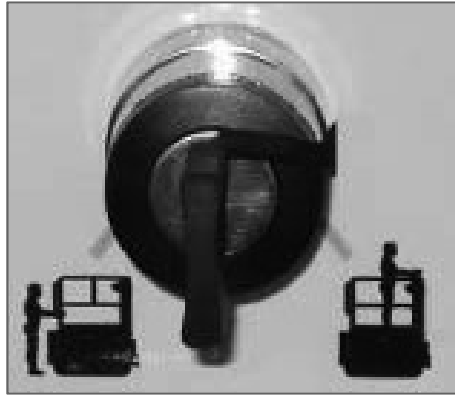

The key-switch functions are:

- (CENTRAL): Machine off-electrical system not powered
- (RIGHT): The platform's entire electrical system starts, including the **mobile pushbutton panel** in the basket. The **ground controls** are excluded.
- (LEFT): The platform's entire electrical system starts. The **ground controls** are enabled and the **basket pushbutton panel is automatically disabled**.

This is followed by a check-control of the indicator lights of the safety system, which flash as described below:

- Indicator light (2): Maximum inclination reached
- Indicator light (5): Basket overloaded

If one or more of the indicators fails to flash, it means that the relative light bulb must be changed.

Once the check-control cycle has terminated, the engine can be started by pressing the related lever (5).

Before climbing in the basket:

1. **Remove the key from the ground control panel and take it with you:**
2. **Make sure that the fuel supply lever is in the ON position (see figure to the side)**

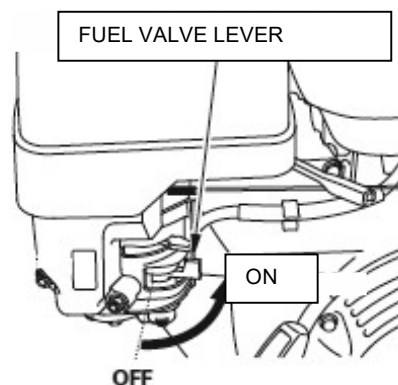

3.

Starting the motor in harsh conditions (e.g., during winter months) is ensured by an electronic fuel injection system.

4.1.6 Emergency starting

If the platform cannot be started as illustrated in the previous section, proceed in the manual mode as described below.

- 1) With the platform fully lowered, turn on the electric panel on the console using the key-switch (17), then move to the combustion engine;
- 2) Take hold of the hand lever and pull it strongly (see photo below). You may have to do this several times before the engine starts.

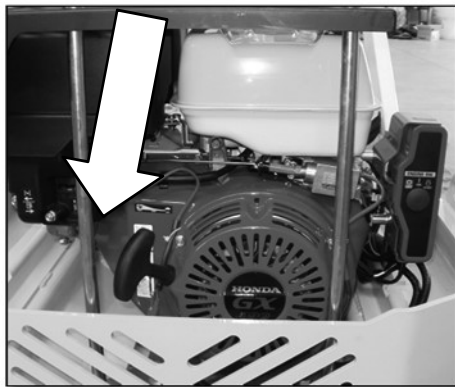

Engine hand-starter lever



4.1.7 Electric motor starting

To start the electric motor and thus the related hydraulic pumps, first connect a sufficiently long cable with three-pole socket that complies with European standard IEC 309 (see photo below) to the socket located near the access ladder.



Type of electrical socket to use for mains hookup



Socket location

The electrical power characteristics **MUST** be as follows:

- Voltage: 220 V / 50 Hz
- Power required: 2.2 kW

Then turn the ignition key in the ground controls (17) to the RIGHT position. Before starting, perform the inspections described in sect. 2.6- *Inspections before use*.

This is followed by a check-control of the indicator lights of the safety system, which flash.

Once this phase is complete, turn the switch (6) on the control panel to the "ELECTRIC ENGINE" position. This enables the electric motor startup up and supply of 220V to the socket in the basket.

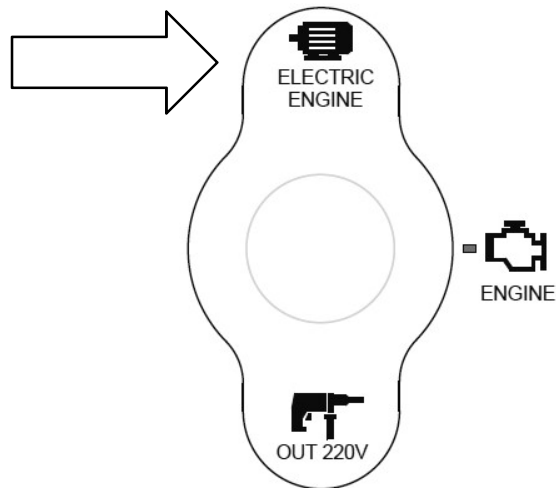

To stop or start the electric motor, set the "ON" lever (5) in the control panel:

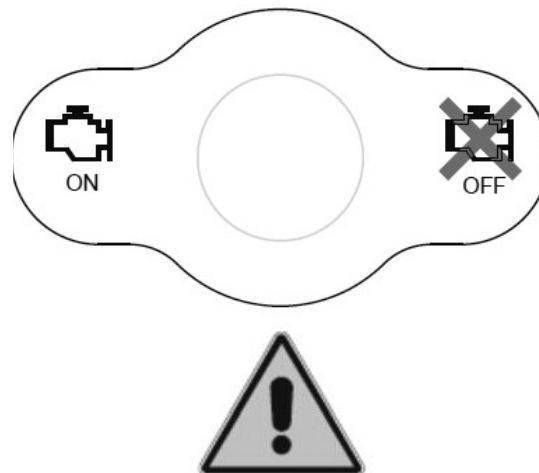

Attention: During operation with the INTERNAL COMBUSTION ENGINE, the 220V socket can be attached to the plug and the switch (6) can be turned to the OUT 220V position. **This makes it possible to use the electricity in the 220V socket in the basket.**

4.1.8 Folding the railings

The ATHENA 850 platform is provided with folding railings which facilitate the transport and the passage inside vehicles. To perform the folding, unlock the pins located on every railing according to a pre-determine sequence.

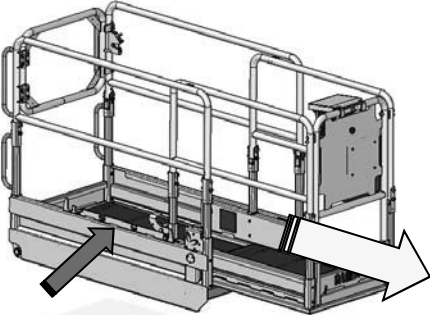
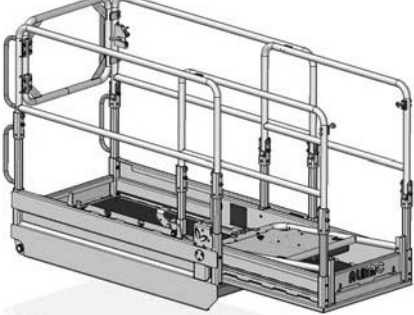
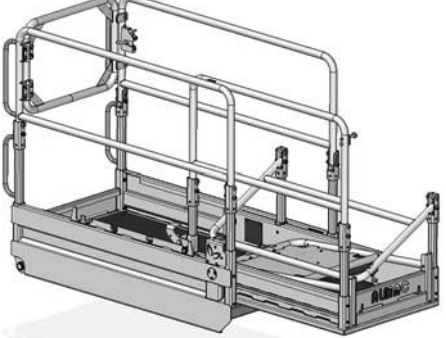
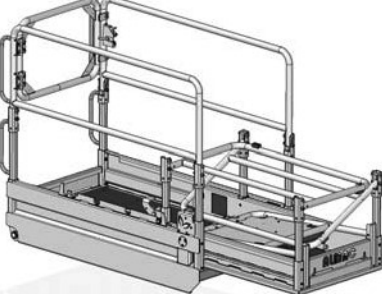
1		<ul style="list-style-type: none">• Expand the basket according to the instructions given in sect. 4.1.4 <i>Expanding the basket</i> until it gets locked in CENTRAL position.
2		<ul style="list-style-type: none">• Remove the remote push-button• Unlock the fastenings of the front railing (see following pages)• Fold the railing according to the figure
3		<ul style="list-style-type: none">• Unlock the fastenings of the expandable basket LH railing• Fold the railing according to the figure
4		<ul style="list-style-type: none">• Unlock the fastenings of the expandable basket RH railing• Fold the railing according to the figure

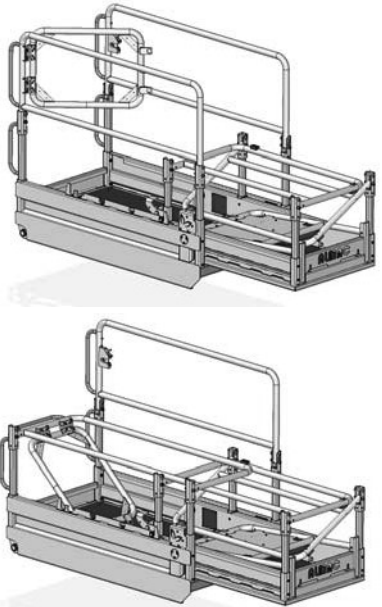
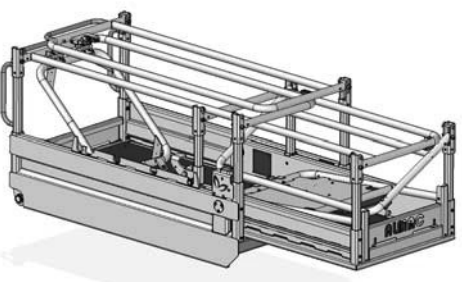
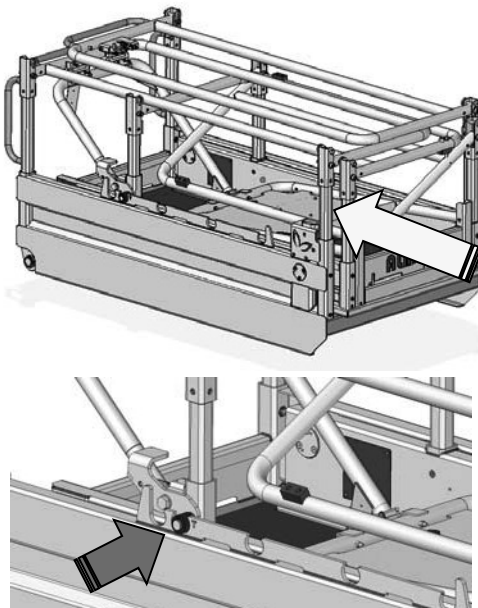
5		<ul style="list-style-type: none"> • Open the access gate according to the picture • Unlock the fastenings of the basket RH railing • Fold the railing according to the figure
6		<ul style="list-style-type: none"> • Unlock the fastenings of the basket LH railing • Fold the railing according to the figure
7		<ul style="list-style-type: none"> • For transport use the position indicated by "T"

UNLOCK THE RAILING FASTENINGS

To unlock the fastenings of the railings:

- 1) Turn the safety catch (A) of the locking pin (B) and then pull it from its seat
- 2) Remove the safety screw (C)
- 3) Once you have extracted all fastenings of the railings, is possible to fold it according to the instructions in the previous pages

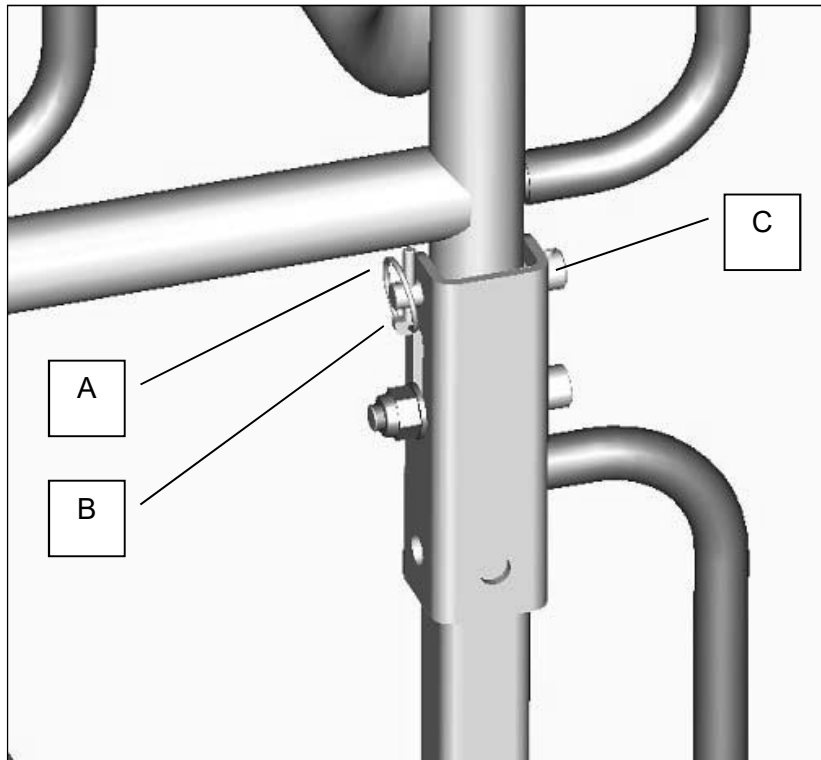

BEFORE STEPPING ON THE PLATFORM IT IS ABSOLUTELY MANDATORY TO RESTORE THE RAILINGS IN VERTICAL POSITION AND FASTENED THEM IN THEIR ORIGINAL POSITION

4.2 Machine operation

4.2.1 Drive and steering

The controls used for driving the platform comprise 2 sensitive joysticks on the control console (see photo below).

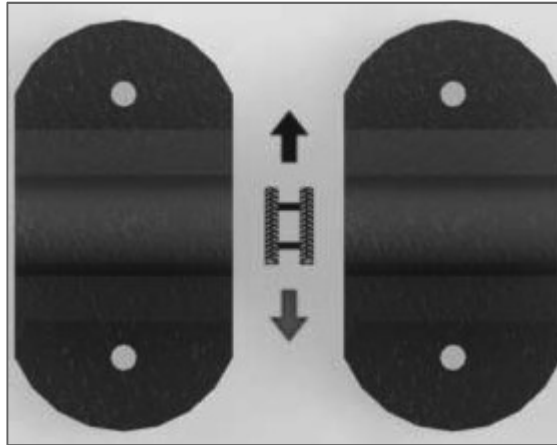

SPEED ADJUSTMENT (TORTOISE/HARE) IS ONLY PERMITTED WHEN THE PLATFORM IS WITHIN THE TRANSPORT HEIGHT (< 2 m floor surface).

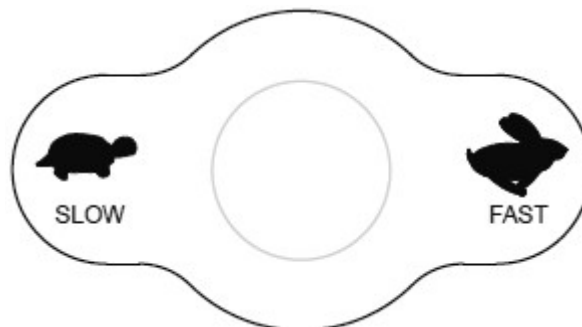

Pushbutton speed control switch

Each lever controls the respective track (right lever - right track, left lever - left track).

Move the lever FORWARDS to drive the platform forwards. Move the lever BACKWARDS to drive in reverse.

You can work with one track at a time, depending on the movement required at that particular moment.

Both movements comply with the maximum safety speeds allowed by the technical regulations in force (point 5.3.1.11, EN280:2013).

The ATHENA 850 platform has a track chassis with hydraulic engines and **negative brakes on the reduction gears** on both tracks. This means that the vehicle remains blocked whenever forward or reverse drive is interrupted.

To turn the platform, move the levers as indicated in the following illustrations.

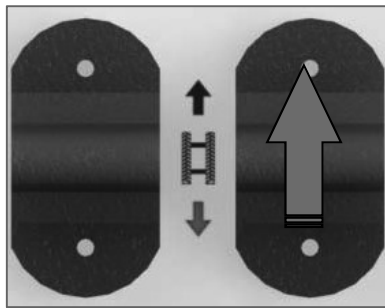

Left turn

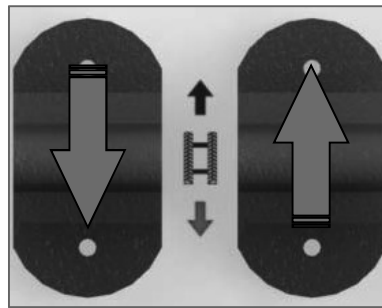

Turn around

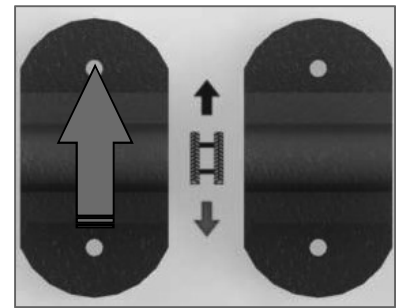

Right turn

Based on the **height of the basket** and the **width of the track** (platform levelling), the various movements are possible.

In the figure below you can see the fields involved that differentiate the "widened track" from the "reduced track".

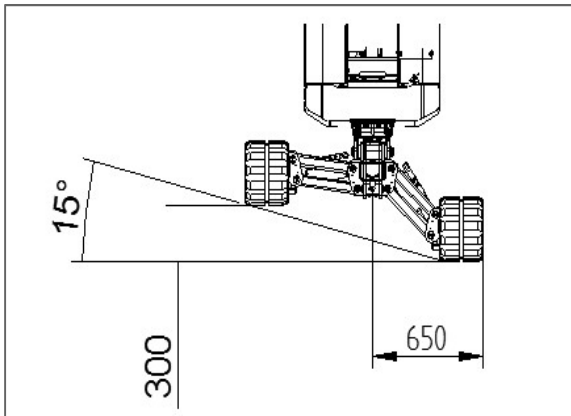

Upon such circumstances is possible to reach the maximum working high and **is possible to move at reduced speed till a working level of 5 mt (3mt platform level).**

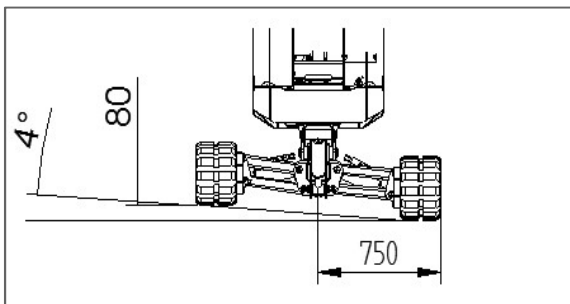

Upon such circumstances is possible to reach the maximum working high and **is possible to move at reduced speed till a working level of 6 mt (4mt platform level).** More than the above to move is definitively prevented

The movement consent light on the control panel provides the following information:

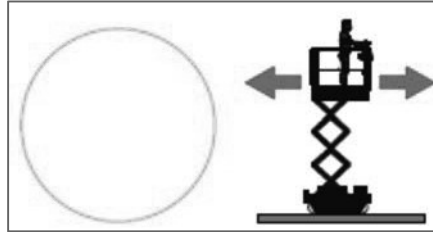

- ON STEADY: Movement OK up to 6 m of work
- OFF: Movement not permitted (track in reduced position)



ATTENTION: If you must drive up a slope, do not change direction when the ground changes from flat to sloping. If this is absolutely necessary, perform the manoeuvre gradually. *Follow the instructions in par. 2.7 - Controls during work.*



IT IS FORBIDDEN to climb on the tracks to attempt any operation that is not allowed or to use the controls in the basket.

IT IS FORBIDDEN to climb on the tracks when the machine is moving.

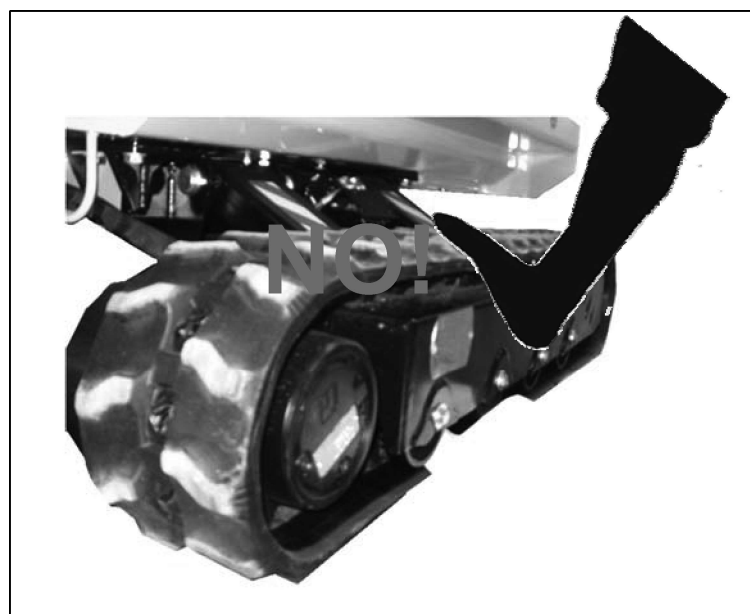



MOVEMENT AT HEIGHTS FORBIDDEN IN THE FOLLOWING CONDITIONS:

- **WET GROUND**
- **SNOW-COVERED AND/OR FROZEN GROUND**
- **DRY ASPHALT BUT WITH SAND, GRAVEL OR OTHER INERT MATERIAL**

ATTENTION: DANGER OF SLIPPING!

4.2.2 Platform levelling

The platform is equipped with an **AUTOMATIC LEVELLING SYSTEM** with dedicated hydraulic cylinders to keep the basket from exceeding the maximum allowed incline, keeping the basket always horizontal to the ground with a range of $\pm 1^\circ$, both longitudinally and laterally (See paragraph 1.6 - Performance).

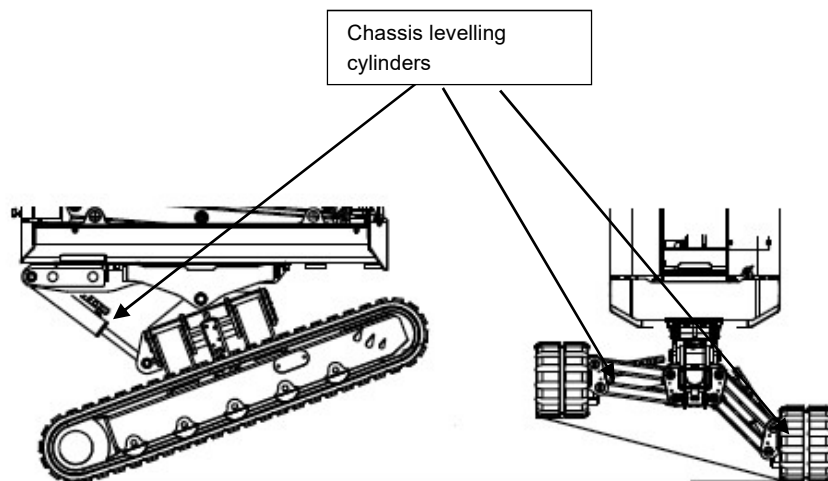

Automatic levelling

The system operates during activation of the "RAISE BASKET" lever.

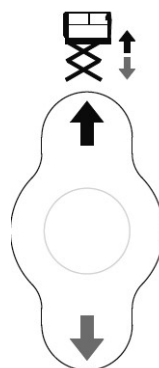

Manual levelling

MANUAL lateral and longitudinal levelling of the platform is only possible within the TRANSPORT HEIGHT (see Par. "1.6- Performance"). This must be done by carefully checking the inclination on the **visual bubble level** located in the basket and using the following controls:

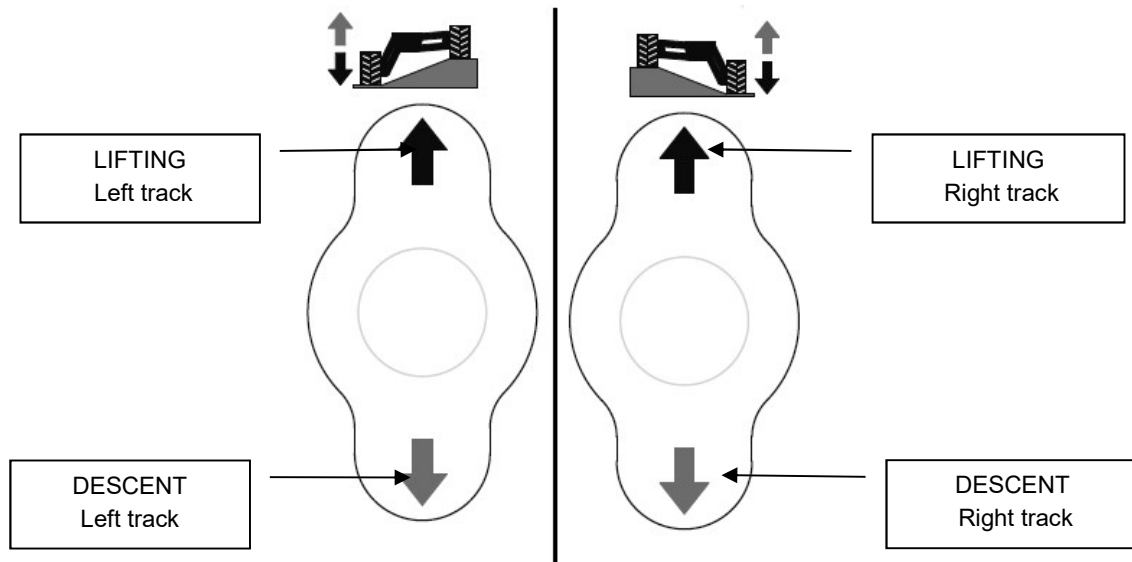

Left track levelling Right track levelling

Using the levelling control for one track, after having levelled the other track, the platform stops automatically when 0° inclination is reached.

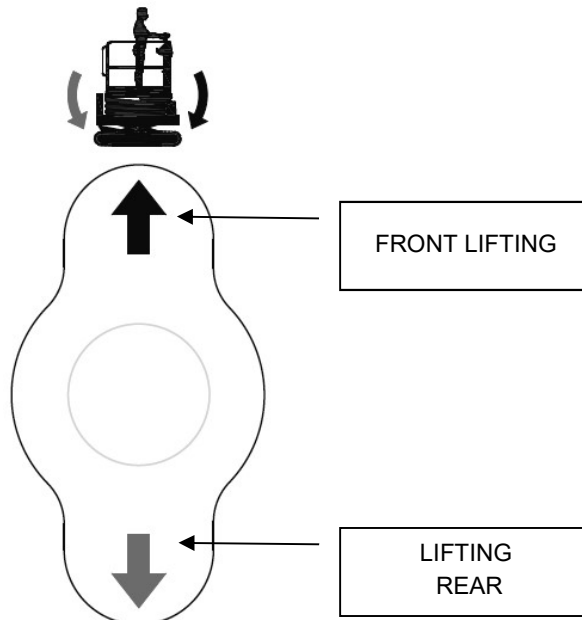

Longitudinal track levelling

If the platform incline remains within $\pm 1^\circ$, both **LATERALLY** and **LONGITUDINALLY**, the basket can be lifted to the maximum height.



MOVEMENT WITH THE MACHINE LIFTED IS AUTOMATICALLY REDUCED TO MINIMUM PROJECT SPEED (Tortoise speed)

WHENEVER THE PLATFORM IS ABOVE THE TRANSPORT HEIGHT AND THE MACHINE INCLINE COMPARED TO THE GROUND EXCEEDS WHAT IS ALLOWED, THE MOVEMENT AND LIFTING CONTROLS ARE AUTOMATICALLY BLOCKED.

The operator must lower the platform to below the transport height and restabilize the machine using the lateral and longitudinal levelling controls.

The configurations the tracked chassis can make are shown below.

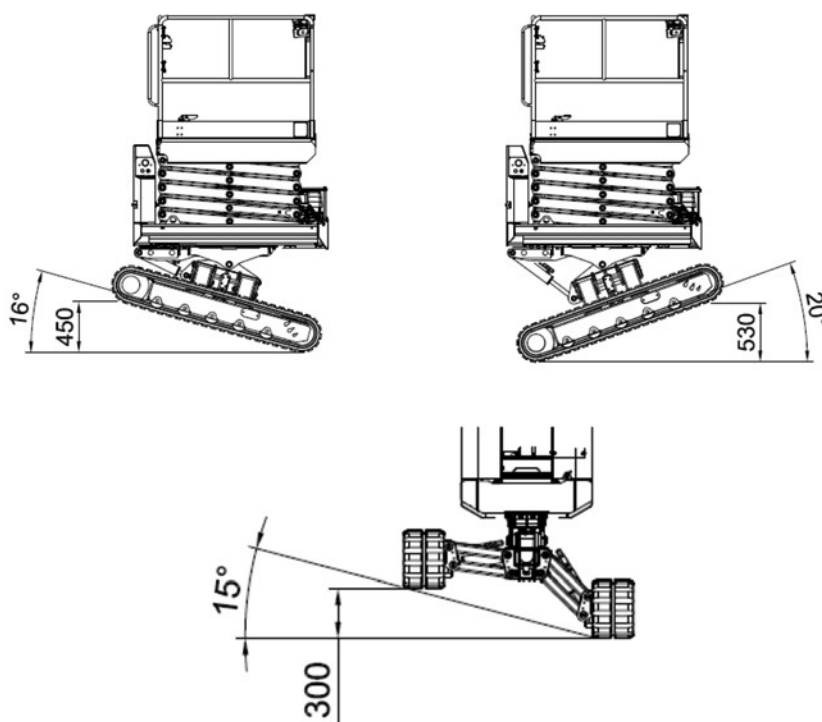

ATTENTION: MANUAL PLATFORM LEVELLING IS ONLY PERMITTED WITHIN THE TRANSPORT HEIGHT OR WITHIN 2 M FROM THE FLOOR SURFACE.

The table below provides more clarity on the allowable configurations described previously.

Configuration summary table

Ground Lateral Inclination	Track	Movement to TRANSPORT height < 2 m	Lifting to MAXIMUM work height	Movement to REDUCED work height 5 m	Movement to REDUCED work height 6 m
< 1°	Widened	YES (slow/fast)	YES	YES (slow)	YES (slow)
< 1°	Reduced	YES (slow/fast)	YES	YES (slow)	NO
>1° <4°	Widened	YES (slow/fast)	YES Automatic levelling	YES (slow)	YES (slow)
>4° <15°	Reduced	YES (slow/fast)	YES Automatic levelling	YES (slow)	NO

Ground Longitudinal inclination	Movement to TRANSPORT height < 2 m	Lifting to MAXIMUM work height	Movement to REDUCED work height 5 m	Movement to REDUCED work height 6 m
< 1°	YES (slow/fast)	YES	YES (slow)	YES (slow)
>1°<20°	YES (slow/fast)	YES Automatic levelling	YES (slow)	YES (slow)

Thanks to the light for the inclination control (see figure below) that indicates the platform inclination status depending upon the light conditions (OFF or ON) (see section 3.3.2- Permitted inclination monitoring device).



AFTER LEVELLING, RAISE THE WORK PLATFORM ONLY AFTER HAVING CONTROLLED, BOTH VISUALLY AND PHYSICALLY MOVING IN THE BASKET, TO HAVE ALL 4 ENDS OF THE TRACKS SUPPORTED ON THE GROUND.

They are to avoid the following situations for both tracks:

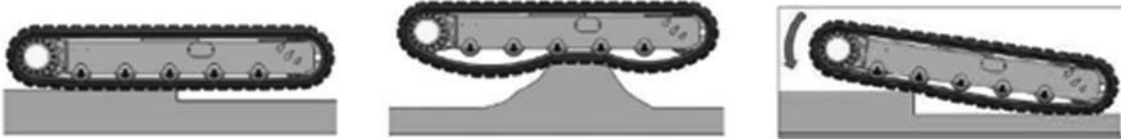

4.2.3 Basket ascent/descent

The basket can be raised using the levers on the control panel. The lifting movement takes place in the gradual mode established by the manufacturer, while descent is performed at fixed speed. **The platform descent can also be performed with the combustion engine off but the electrical panel ON.**

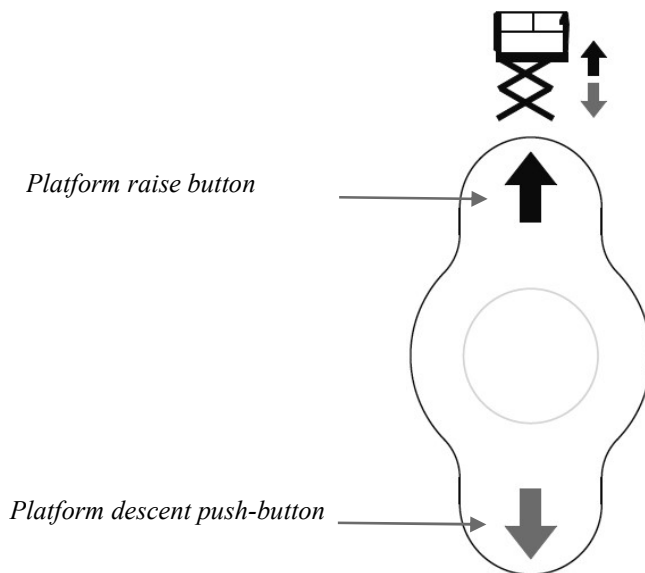

The ANTI-CRUSHING device will function during this operation, for the purpose of preventing bystanders near the machine from being injured (*see sect.3.3.1 Anti-crushing device*).

4.2.3 Manual warning buzzer

Use the push-button on the pushbutton panel to operate the buzzer. It must be used whenever persons working or moving around the platform area must be warned that platform movements are in progress.

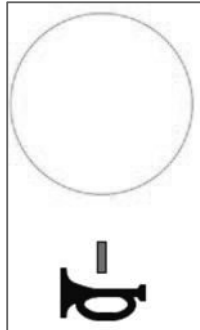

Warning buzzer

4.2.4 Control and diagnostic display



The ground control console features a tool, fitted in the middle position, that allows you to view the status of the machine.

This tool also displays any anomalies and/or errors.

CODE	DESCRIPTION
90	SUPPLY VOLTAGE LESS THAN 9V
91	SUPPLY VOLTAGE MORE THAN 17V
92	EPROM MEMORY ERROR
93	CAN NETWORK ERROR
40	REDUNDANCY ERROR INCLINOMETER BASE
30	REDUNDANCY ERROR ANGOLOMETER SCISSOR
60	REDUNDANCY ERROR CHASSIS LIMIT SWITCH
70	REDUNDANCY ERROR PRESSURE SENSORS
41	NO RECEPTION FROM INCLINOMETER BASE 1
31	NO RECEPTION FROM ANGOLOMETER SCISSOR 1
61	NO RECEPTION FROM CHASSIS LIMIT SWITCH 1
71	NO RECEPTION FROM PRESSURE SENSORS 1
42	NO RECEPTION FROM INCLINOMETER BASE 2
32	NO RECEPTION FROM ANGOLOMETER SCISSOR 2
62	NO RECEPTION FROM CHASSIS LIMIT SWITCH 2
72	NO RECEPTION FROM PRESSURE SENSORS 2
10	NO RECEPTION FROM REMOTE CONTROL

Pressing the display keys you can see the various screens.



E = Total hours worked in electric motor



D = Total hours worked in Hatz / Honda engine

4.2.5 Easy-Drive System (ED-S)

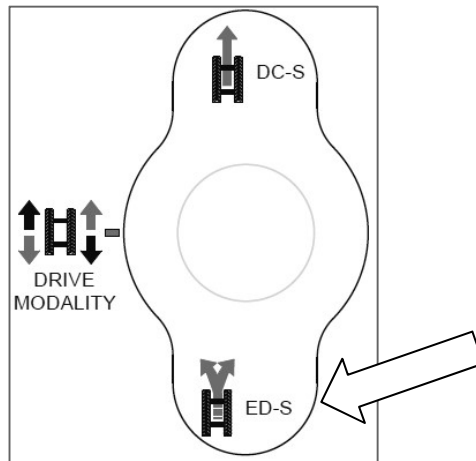

Moving the switch on the pushbutton panel to the "ED-S" position activates a special function that allows you to control the rotation on the platform, especially when operating on cultivated or grassy terrain, so that the tracks do not rip the cultivation during right or left rotation. When activated, the function controls not only the track involved in the rotation but also the rotation of the other track in a controlled manner.

4.2.6 Direct-Control System (DC-S).

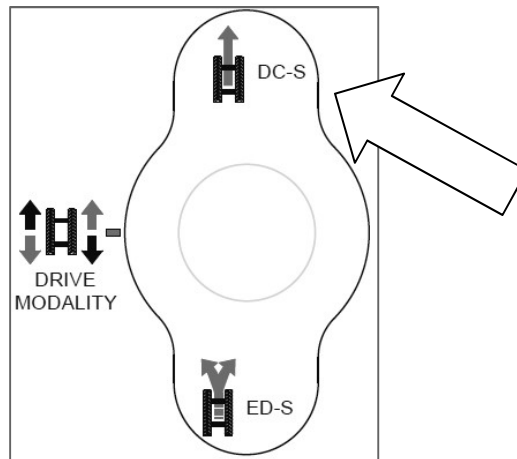

By moving the switch on the pushbutton panel to the "DC-S" position you can use only the Joystick to move in the driving direction, maintaining a straight trajectory without having to correct the direction with the other joystick.

This function is especially useful when loading the platform on ramps.

4.3 Ground control with mobile pushbutton panel

The ATHENA 850 is equipped with a mobile pushbutton control panel that besides allowing normal operation of the basket also can be removed temporarily and used on the ground ONLY FOR TRANSPORT OPERATIONS.



Examples of ground control with the



Pushbutton panel



Before performing the operation, make sure the platform is IN THE COMPLETELY LOWERED TRANSPORT POSITION

Once the pushbutton panel has been removed from the basket, use the strap to carry it **FIRMLY AND SECURELY** to avoid manoeuvring errors.



When driving in this condition BE CAREFUL TO NOT ENTER IN CONTACT WITH THE PLATFORM TRACKS. REMAIN THE PROPER DISTANCE AWAY, USING THE FULL LENGTH OF THE PUSHBUTTON CONTROL PANEL CABLE

Once the transport phase is complete, replace the pushbutton panel.

4.4 Use of ground controls

The ATHENA 850 has a command console located on the chassis in the rear of the machine. These controls are useful for the operator on the ground for platform maintenance or for emergency situations (red mushroom button).

The ground controls are protected against unauthorized use by a key that is used to activate the 3 way switch.

THE KEY MUST ALWAYS BE AVAILABLE TO THE RECOVERY OPERATOR OR THE INDIVIDUAL WHO PERFORMS OPERATIONS ON THE GROUND.

Involuntary activation of the ground controls is prevented by the automatic key selection: turning it to the "basket controls" (RIGHT) position automatically disables the ground controls while selecting the "ground controls" position (LEFT) automatically disables the command console.



Attention: only personnel who have been properly trained and skilled in using the controls may use those controls.

IT IS FORBIDDEN to stay inside the basket while another operator performs manoeuvres with the ground controls.



Symbol	Identification	Function
1	3P Key switch	LEFT position = electrical panel on - mobile pushbutton panel disabled - ground controls enabled
		CENTRAL position= platform off
		RIGHT position = electrical panel on - ground controls disabled - mobile pushbutton panel enabled
2	Button	Platform emergency button
3	Return lever	Basket ascent/descent
4	Return lever	Starting/stopping the electric or internal combustion engine

4.5 Stopping the machine

4.5.1 Normal stopping

During normal platform use, releasing the MOVEMENT joysticks (10 and 11) stops the movement. Each track has a braking system that prevents the machine from moving unless hydraulic pressure is exercised to disengage it (see sect. 4.2.1-Drive and steering).

Releasing the RAISE platform or LOWER platform (15) button in normal working conditions, stops the related movement.

Platform disabling and recovery is done as follows:

1. Stop the platform as described above
2. Cover the mobile pushbutton panel with the casing (see photo below)
3. Climb down from the basket using the ladder
4. Set the switch to the 3 position on the ground controls in the central position and then remove the key
5. Switch off power to the battery



View of the pushbutton panel with the casing

4.5.2 Emergency stop

In abnormal circumstances or situations where all machine movements must be stopped, the operator can IMMEDIATELY STOP all the machine functions by pressing the MUSHROOM-SHAPED push-button on the panel or on the GROUND CONTROLS (see photo below).



4.6 220 V electrical socket

- Voltage characteristics: 220 v – 800 w
- Safety: safety device (cut-out)

The power socket (optional) is installed in the basket, alongside the console (see photo below). Its purpose is to power tools with voltage and power specifications that comply with the indications above. To enable current to the socket **with the combustion engine running**, you must turn the switch (6) to the "OUT-220 V".

With **electricity**, the socket is usually active.

During operation with the INTERNAL COMBUSTION ENGINE, the 220V socket can be attached to the plug and the switch (6) can be turned to the OUT 220V position. **This makes it possible to use the electricity in the 220V socket in the basket.**

A device automatically disconnects the power supply (cut-out) in the event of a short-circuit and/or over-voltage.

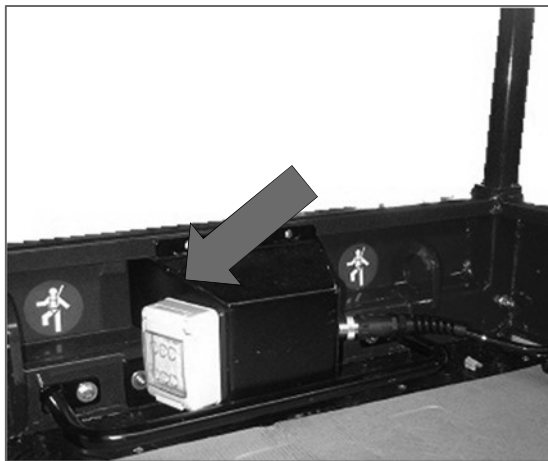

Power socket 220V

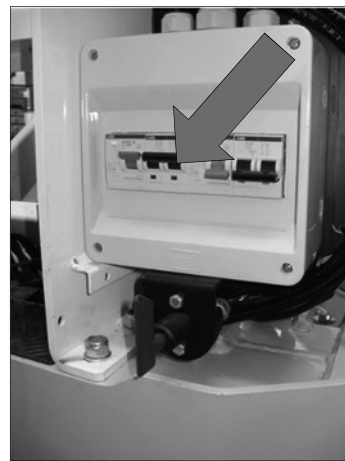

Safety switch (cut-out)

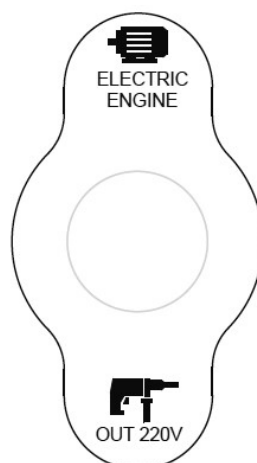

220v current enabling switch

4.7 Storage compartment

A compartment, which can be opened by hand (see photo alongside) is provided in the platform, under the control console. It contains:

- this Use and Maintenance Manual

Personal objects can also be stored in the compartment, so long as they are of a suitable size.



Emergency procedures

5.1 Emergency manual descent

Following a failure in the electrical system or hydraulic circuit, the platform DESCENT manoeuvre can be performed from any height by means of the emergency control at ground level.

In this case, the operator on the ground uses the hydraulic valve control located in the rear of the platform near the access ladder (**remember that safe use of the platform requires at least one operator on the ground**).

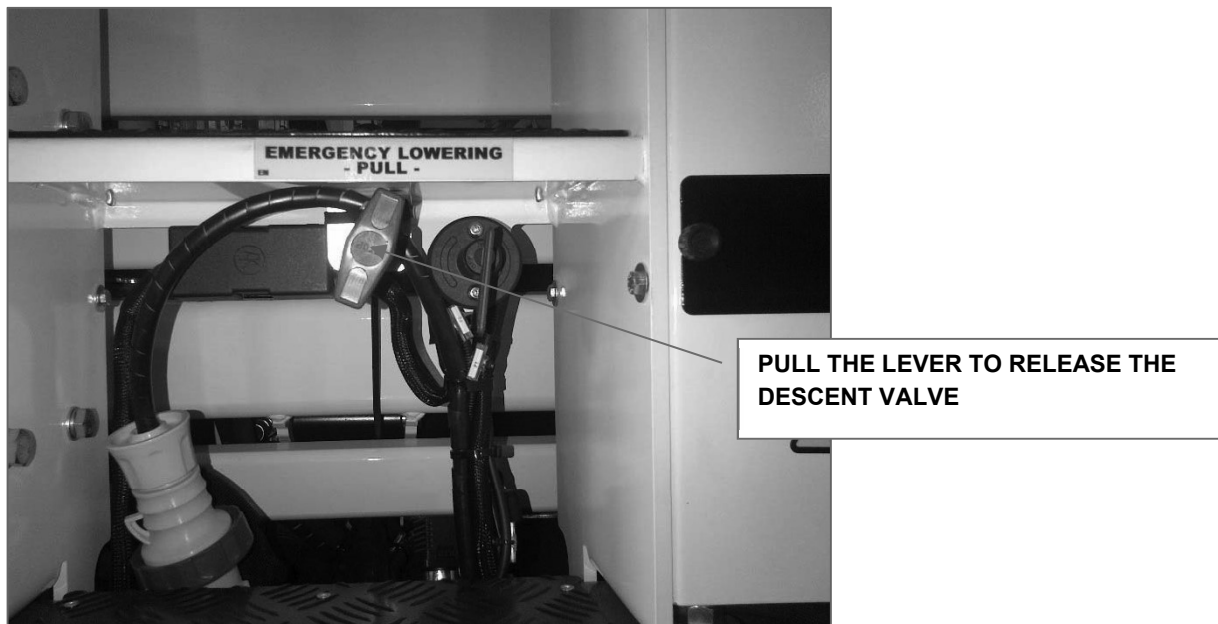

ATTENTION: THIS MECHANISM MUST ONLY BE USED IN AN EMERGENCY, i.e. ELECTRICAL OR HYDRAULIC FAILURE.

5.2 Transport of the machine in an emergency

If the combustion engine and, thus, the hydraulic circuit cannot be started, emergency transport of platform ATHENA 850 is performed in the same way as manual transport.

Use a CE certified beam (not included) that should have a vertical distance of 350 mm between the hook and chain and, using hooks and steel ropes hooked to the holes marked with signs (see photo below). The ropes must possess safety factor 5.

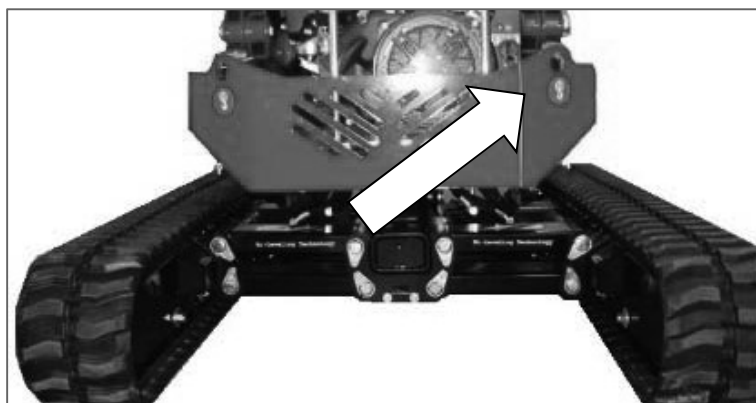
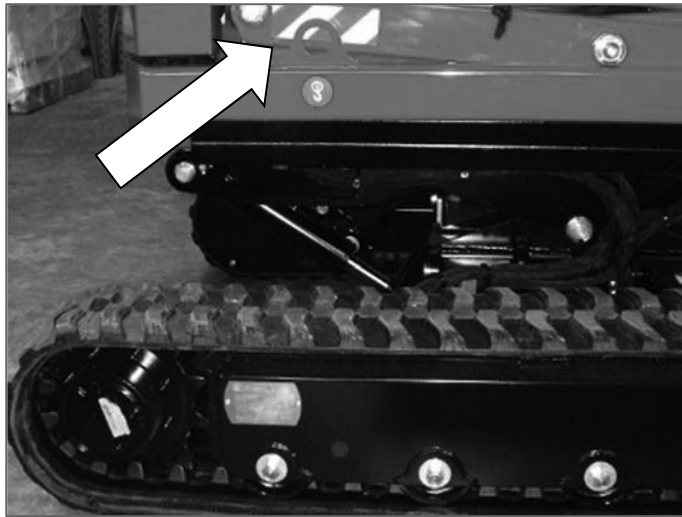

Note: Once the machine has been loaded onto the vehicle, it must be fastened in place by means of the holes used for lifting

Note: Make sure that the platform is FULLY LOWERED before transporting the machine.

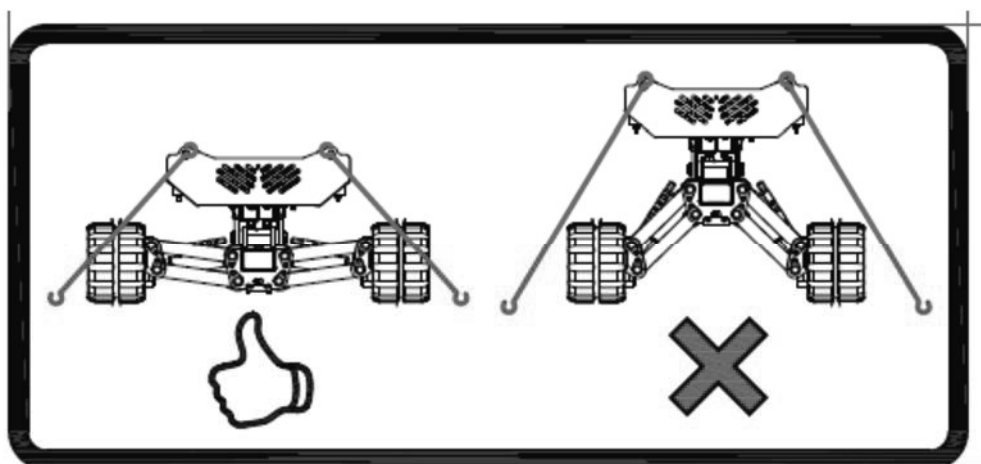

6.1 General maintenance

The main maintenance interventions and the frequencies with which they must be carried out are given in the chart below.



Warning: All maintenance operations must be performed as indicated in *Chapter 2 Information regarding safety*. Most especially, maintenance must only be carried out after the emergency push-button has been pressed, the engine turned off and using individual protective equipment

Warning: Disconnect the machine from all power sources

Warning: It is mandatory to perform all MEWP movements required for inspections/maintenance from the ground and without persons in the basket. When checking machine operation from the basket, the required movements must be performed as near to the ground as possible.

Note: Use of spurious spare parts, or parts that have not been approved by the manufacturer voids the warranty and relieves ALMAC S.r.l. from all liability.

Note: Modifications or variations to the MEWP are forbidden unless authorized by the manufacturer.

Note: All maintenance work that is not described in this manual must be authorized by ALMAC S.r.l. and must be performed by personnel authorized by this latter.



Warning: *DO NOT USE THE MACHINE IN CASE ONE OF ITS MECHANICAL OR HYDRAULIC ELEMENTS IS FAULTY. DO NOT USE THE MACHINE IF A SAFETY CONTROL DEVICE AMONG THOSE DESCRIBED IS FAULTY!*

IMMEDIATELY NOTIFY N ALMAC S.r.l CUSTOMER ASSISTANCE CENTRE

CHECKS PRIOR TO USE

Prior to commissioning and before each use the machine must undergo the visual and functional checks given below. Moreover, at the start up the machine safety condition must be also checked.

VISUAL CHECK	CHECK OPERATION
<ul style="list-style-type: none"> Ensure there are no hydraulic oil leakages from the piping or other hydraulic components Ensure there are no electrical conductors cut and/or disengaged Ensure no bolts, nuts and plug ring are loose and/or missing Ensure there are no cuts and/or uneven wear on the tracks Ensure there are no damages, deformations or cracked welds Make sure the user's manual, the plates and warning signs are present 	<ul style="list-style-type: none"> Check the oil level inside the tank Ensure the battery that starts up the combustion engine is charged Ensure all plates and warning signs are present and legible Engage the emergency buttons to make sure no operation is possible. Once checked the emergency buttons, restore their position to ON. Check the proper functioning of the safety devices. Lift and lower the platform a few times to ensure its works properly Make sure the buzzer gets enabled during platform descent and translation. During translation, check the proper working of the brakes by releasing the joysticks. Push the buzzer and make sure it works

ORDINARY MAINTENANCE SCHEDULE TABLE	A	B	C	D	E	F	G	H
		10	50	100	250	500	1500	
Visual and functional checks as specified	X							X
Discharge filter cartridge replacement							X	X
Suction filters replacement							X	X
Grease the runners			X					X
Checking the hydraulic oil level	X							X
Change the hydraulic oil							X	
Track reduction gear oil level inspection						X		X
Replace oil in the track reduction gear							X	
Check the oil level in the engine	X							X
Change the motor oil * (after the first 20 hours)				X				
Replace engine oil filter.*				X				X
Clean the engine air filter.*			X					X
Replace engine air filter.*					X			
Track inspection and tensioning	X							X
Check the condition of the tracks	X							X
Check the runners and sliding wheels					X			
Check the tightening of nuts and bolts				X				
Check using a torque wrench the tightening of screws and bolts for fixing of the tracked chassis to the machine frame, the screws M16 class8.8 tightening torque 193 Nm (after the first 50 hours)					X			
Check and adjust the plug rings				X				
Structural inspection (visual)	X					X		X
Structural inspection (through checking of metal parts and welds)						X		X
Check the overload monitoring device				X				X
Manual emergency devices	X							X
Check the combustion engine battery	X							X
Check the working of the differentials						X		X
Check the limit switches				X				X
Check the inclinometers				X				X
Check and replace the fuses					X			X

KEY

- A. whenever the machine is used
- B. daily or every 10 hours
- C. weekly or every 50 hours
- D. monthly or every 100 hours
- E. every two months or each 250 hours

- F. quarterly or every 500 hours
- G. annually or every 1500 hours
- H. after long shut-down (30 days)

* Refer to the engine use and maintenance manual

6.2 Checking and tightening screws, bolts, nuts, plug ring nuts

The operation of the following components must be checked. If necessary, the parts must be tightened with the appropriate tools as indicated in the charts on the following pages.

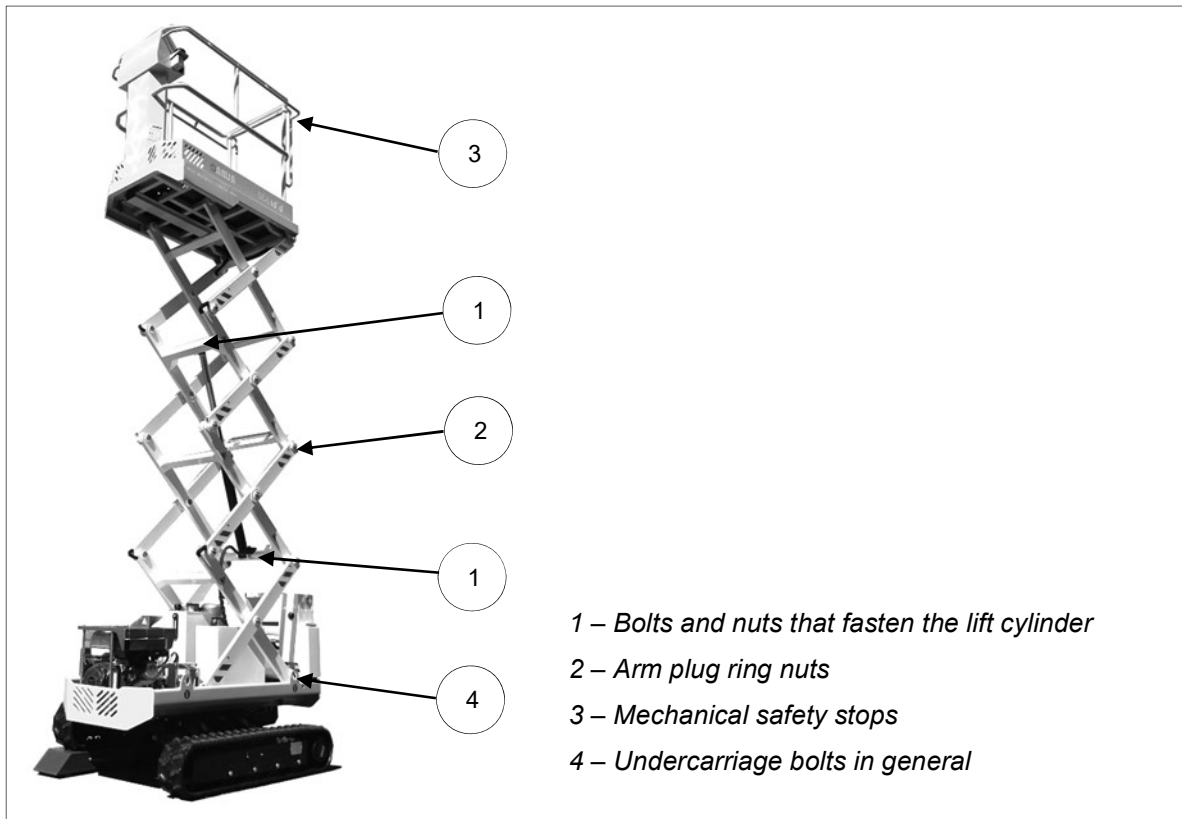

Clamping forces and tightening torque for bolts with DIN 13 metric thread

Resistance class in accordance with DIN/ISO 898			8.8		
Yielding point Rp 0,2 N/mm ²			640 for ≤ M16 / 660 for ≥ M16		
Metric thread ISO	Cross-section of the powered zone	Cross section of the thread	Clamping force	For hydraulic and electrical torque wrench	Ma' = 0.9 MD* for the wrench
DIN 13	AS mm ²	A3 mm ²	FM kN	MA Nm	MA' Nm
M12	84.3	76.2	38.5	87	78
M14	115	105	72	140	126
M16	157	144	91	215	193
M18	193	175	117	300	270
M20	245	225	146	430	387
M22	303	282	168	580	522
M24	353	324	221	740	666
M27	459	427	270	1100	990
M33	561	519	335	1500	1350
M36	694	647	395	Bolt determined by measuring the yielding	
M39	817	759	475		
M42	976	913	542		

6.3 Visual and structural inspection

Visually check the following points according to the schedule indicated in the general chart. Immediately inform a maintenance technician if faults are discovered.

- **Condition of basket railings**
- **Condition of ladder**
- **Condition of lift structure**
- **Rust**
- **Tyre condition**
- **Oil leaks**
- **Ring nuts or retainers on the structure**

6.4 Deformation to tubes and cables

Visually check at the frequencies indicated in the general chart to make sure that the articulation point of the hydraulic hoses and electric cables are not misshapen or damaged. Examples of such faults are shown on the photos below.



Damaged hydraulic hose pipe



Damaged electric cable

6.5 Greasing of articulations and runners

Grease these parts at the frequency indicated in the general chart and EACH TIME that the following operations are performed:

- after the machine has been washed
- after a long idle period
- after use in particularly harsh conditions, e.g. damp or dusty places, marine environments, etc...

Grease the following points (see photos below):

- 1) the runners of the extensible structure under the basket
- 2) the runners of the extensible structure on the chassis

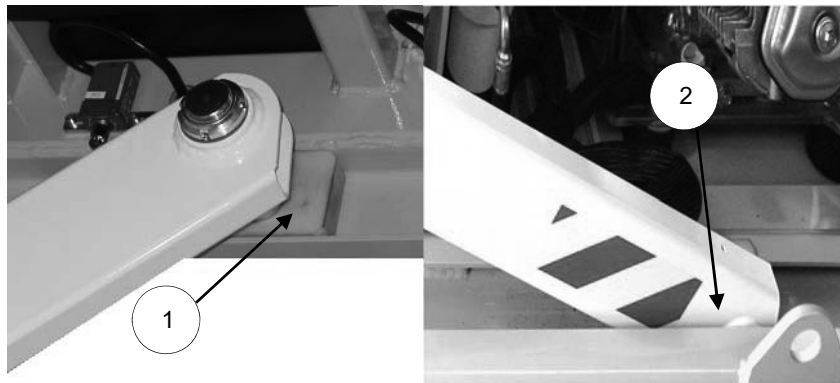

Remove all dirt from the parts before greasing.
Use grease type **ESSO BEACON-EP 2** or equivalent.

6.6 Hydraulic tank oil level inspection

Check the hydraulic oil level on the level gauge on the reservoir (see next photo).

The correct oil level should be checked with the machine in the configuration as shown in the following pictures.

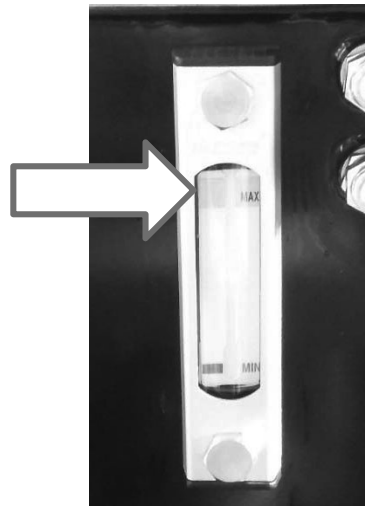
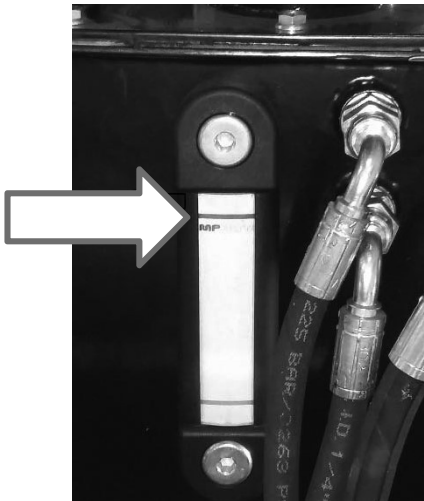

6.7 Hydraulic tank oil changes

In accordance with the maintenance table, replace the hydraulic oil in the tank.

Replace using a manual pump or electric (not included in delivery) and using the filler cap located on top of the tank. Prepare a suitable container to enable the collection and subsequent disposal of used oil.

RECOMMENDED HYDRAULIC OIL

It is advisable to use “SHELL TELLUS S2V68” oil with the following specifications:



Manual pump (example)



Electric pump (example)

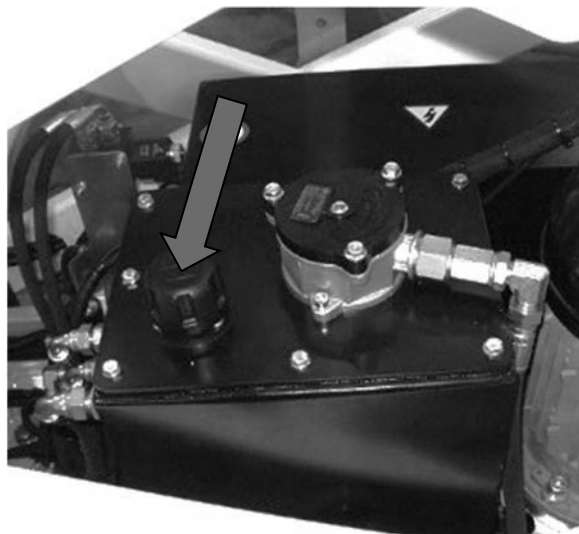

Filler cap

6.8 Inspection of lift circuit pressure relief valve operation

Check track tension at the inspection frequency indicated in the general chart. This valve acts as a supplementary protection device for the electronic overload device and prevents the platform from lifting once the nominal load has been exceeded by 50%.

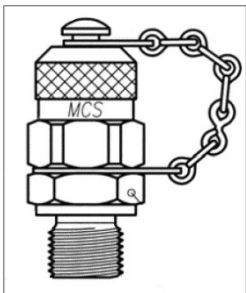
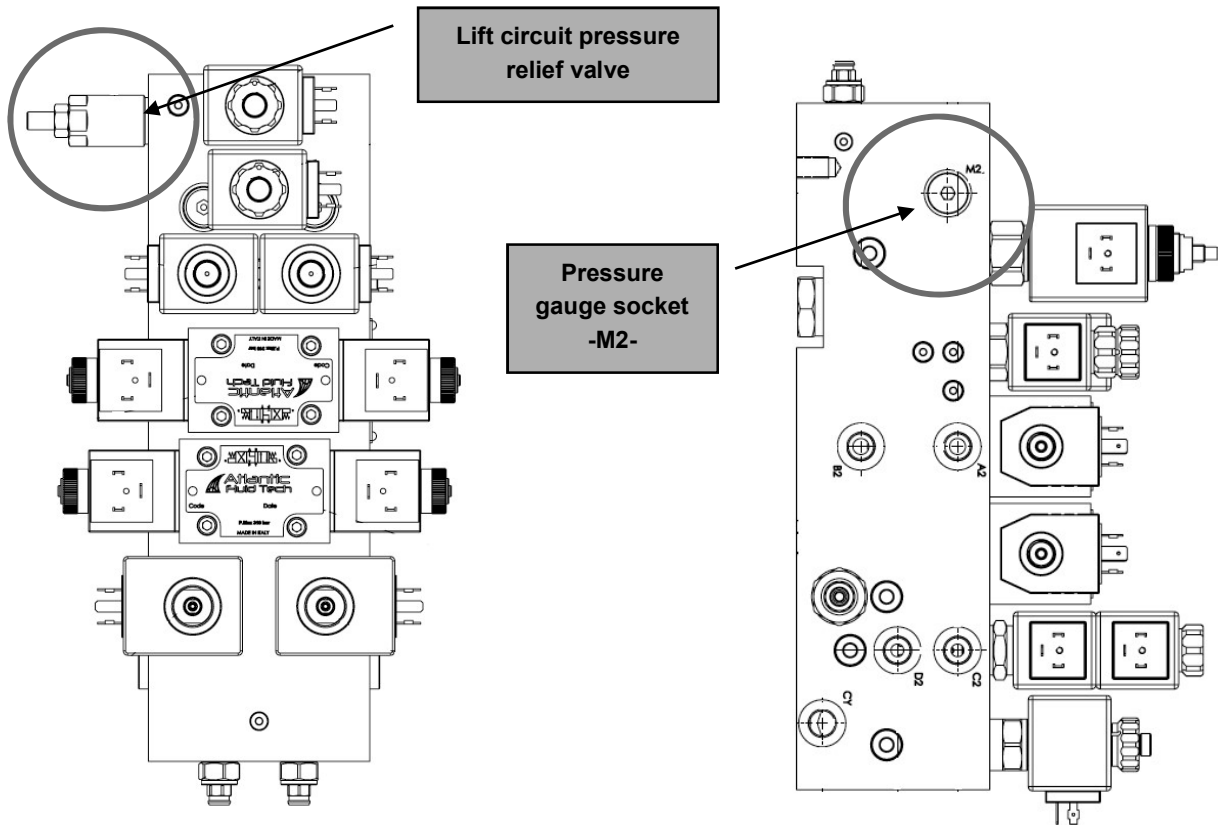

To perform the test, unscrew the inlet plug “M1” on the hydraulic valve unit (*see drawing above*) and fit on a 1/4” Gas pressure gauge union as shown in the figure alongside.

Now screw a tube for the pressure gauge fitting and a pressure gauge with 250 bar full scale into the union described above.

While one operator remains on the ground so as to check the pressure relief valve setting, another operator must work from the console in order to:

- start the platform and combustion engine
- press the platform "descent" button (16) until it reaches the limit and hold it down. This activates the pressure relief valve of the lift circuit.
- Read the pressure on the gauge, which should be 190 bar \pm 5 bar

The valve is calibrated during the testing operations performed by ALMAC S.r.l. and should not require further adjustment unless:

- the hydraulic circuit is replaced
- the actual pressure relief valve is replaced.

In these cases, the valve must be calibrated by **SPECIALIZED PERSONNEL** according to the monitoring procedure described above. Using the appropriate tools, unscrew the lock nut (1) and tighten or loosen the adjuster screw (2) until the indicated pressure level has been reached. Once the adjustments have terminated, tighten the lock nut (1) to hold the screw in position.

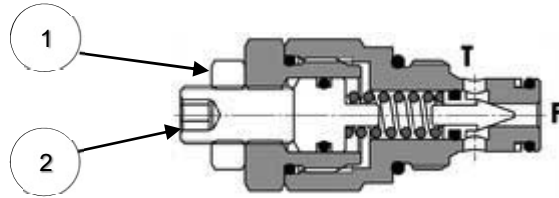

Diagram of the pressure relief valve



Attention: Calibration operation must only be performed by **SPECIALIZED personnel. It must not be done by a generic operator.**

6.9 Battery

6.9.1 General recommendations

The battery is an essential component for machine operation. It is important to ensure that it remains in a good condition over time since this will lengthen its working life, limit any problems that may arise and reduce the running costs of the machine.

Comply with the following instructions:

- ☼ CHARGE THE BATTERY IN A VENTILATED PLACE AND OPEN THE VENT CAPS TO ALLOW THE GAS TO ESCAPE DURING THE CHARGING OPERATION
- ☼ KEEP OPEN FLAMES WELL AWAY FROM THE BATTERY SINCE EXPLOSIVE GASES COULD FORM
- ☼ DO NOT MAKE TEMPORARY ELECTRICAL CONNECTIONS OR ONES THAT FAIL TO COMPLY WITH THE REGULATIONS
- ☼ DO NOT PLACE TOOLS OR ANY OTHER METAL OBJECT ON THE BATTERY
- ☼ CLEAN ANY ENCRUSTATIONS FROM THE BATTERY TERMINALS AND ALWAYS TIGHTEN THEM CORRECTLY

☀ ALWAYS KEEP THE BATTERY CLEAN, DRY AND FREE FROM OXIDATION

☀ IF THE BATTERY IS CHANGED, ALWAYS COMPLY WITH THE INSTRUCTIONS SUPPLIED WITH IT

6.9.2 Maintenance

ALMAC S.r.l. installs “**maintenance-free**” batteries as part of the standard equipment on all ATHENA 850 models. These batteries feature construction technology that reduces water consumption to a considerable extent and maintains the electrolyte for the entire life cycle of the batteries themselves.

6.9.3 Recharging

The batteries installed as part of the standard equipment on all ATHENA 850 models are generally equipped with an indicator that provides information about the battery charge depending on the colour:



When charging, gas develops that in certain conditions can create EXPLOSIVE ATMOSPHERES.

Always recharge batteries in well ventilated places that conform to standards EN 60079-10 (IEC 31-30), where there is no risk of fire outbreaks and where suitable extinguishers are ready to hand.

Connect the battery charger to an electric power supply that conforms to the following specifications:

- **Voltage: 230 v ± 10%**
- **frequency: 50-60 Hz**
- **Functional earthing system**

Proceed as described below to access the battery:

- 1) raise the extensible structure of the platform using the relative controls (see previous pages)
- 2) block the extending structure using the procedure described in sec. **2.9 Safety regulations during maintenance**
- 3) Remove the casing of the electric panel compartment (1) using appropriate tools
- 4) Unscrew the cables connected to the battery terminals and insert the battery charger clamps
- 5) Disconnect the battery charger when the relative indicator shows that the battery is charged.
- 6) Comply with the GENERAL RECOMMENDATIONS described in section 6.9.1

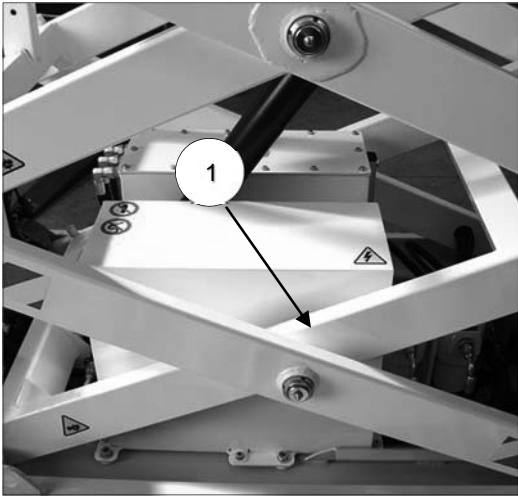

Electrical panel casing



Battery

6.10 Hydraulic filter replacement

Replace the discharge filters of the hydraulic circuit at the frequencies indicated in the general chart.

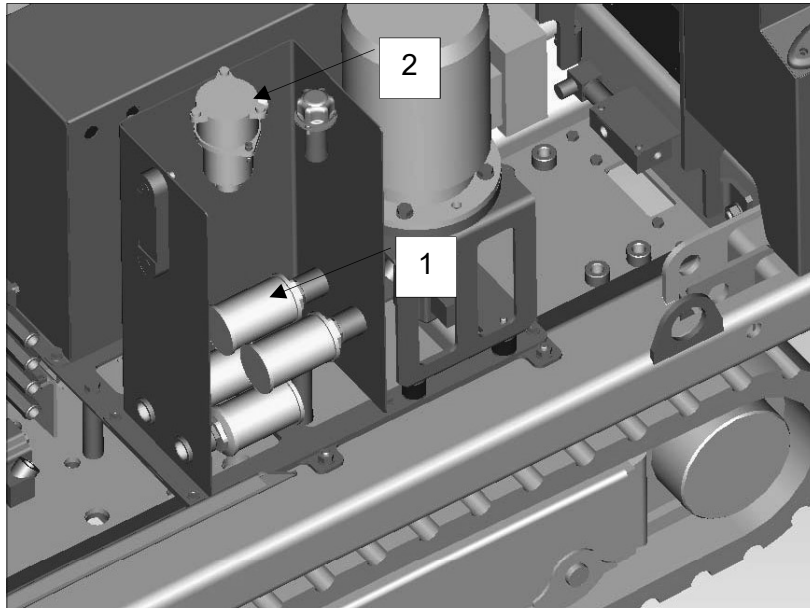

The figure above shows the positions of the discharge filters (1), screwed inside the hydraulic tank or those of the return filter (2) located on the top of the tank itself.

6.10.1 Discharge filter replacement

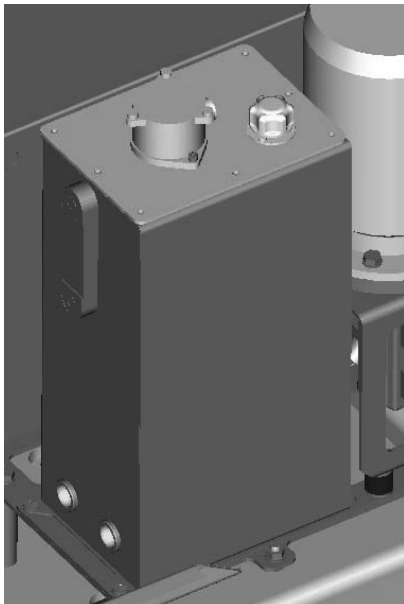

To replace the discharge filters located inside the hydraulic tank, proceed as follows:

- 1) Arrange the machine with the extending structure lifted and block it with the special tool for maintenance (see **sec. 2.9 Safety regulations during maintenance**). **Now turn it off and deactivate the electric panel.**
- 2) Empty the hydraulic oil reservoir
- 3) Unscrew the blocking screws (3) on the hydraulic tank lid and remove it from its housing
- 4) Unscrew the filter cartridge (1). Take care of the seals and/or O-rings.
- 5) Remove the filter (1) and fit a new one in its place.
- 6) Work through the instructions above in reverse order to restore the machine to its normal operating conditions.
- 7) Seal the lid with sealing paste
- 8) Fill the hydraulic oil reservoir with oil and check the level.

6.10.2 Return filter replacement



To replace the return filter located above the hydraulic tank, proceed as follows:

- 1) Arrange the machine with the extending structure lifted and block it with the special tool for maintenance (see **sec. 2.9 Safety regulations during maintenance**). **Now turn it off and deactivate the electric panel.**
- 2) Unscrew the blocking screws (4) on the filter and remove it from its housing
- 3) Unscrew the filter cartridge (5). Take care of the seals and/or O-rings.
- 4) Remove the cartridge (6) and fit a new one in its place.
- 5) Work through the instructions above in reverse order to restore the machine to its normal operating conditions.

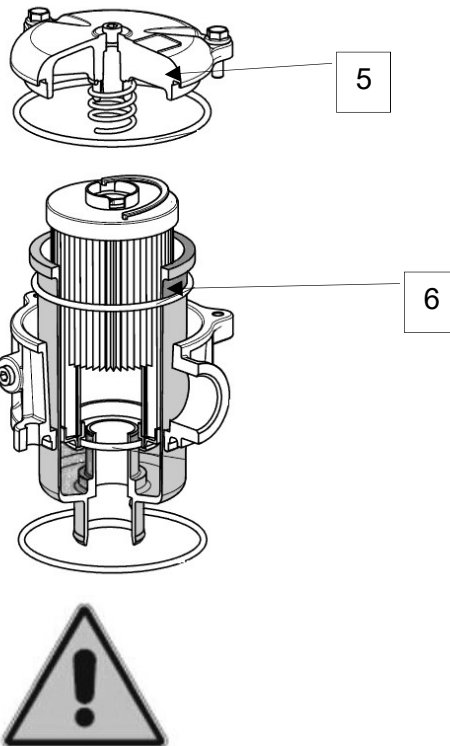

Attention: during operations some oil could spill. Remove spilt oil with a cloth or place a vessel underneath so that the oil drains into it.

ONLY USE GENUINE SPARE PARTS when replacing the filters. Contact the **ALMAC technical assistance service**.

Do not reuse used oil. Do not dispose of it in the environment. Used oil must be disposed of as required by the laws in force.

6.11 Inspection of inclinometer operation

Perform a functional inspection of the platform's safety inclinometer at the inspection frequency indicated in the general chart.



Safety inclinometer

The platform must have the track WIDENED $W=1500$ mm (chassis not levelled).
To test the electronic inclinometer, tilt the platform by placing the shims indicated in the figure below, underneath the tracks near the roller centre line.
To do this, lift the machine from ground level using suitable equipment and the anchorage points indicated by the relative signs:



CHECK WITH 1° OF LATERAL INCLINATION

Tilt the platform by placing the shims indicated in the figure below, underneath the tracks near the roller centre line (inclination reached $>1^\circ$):

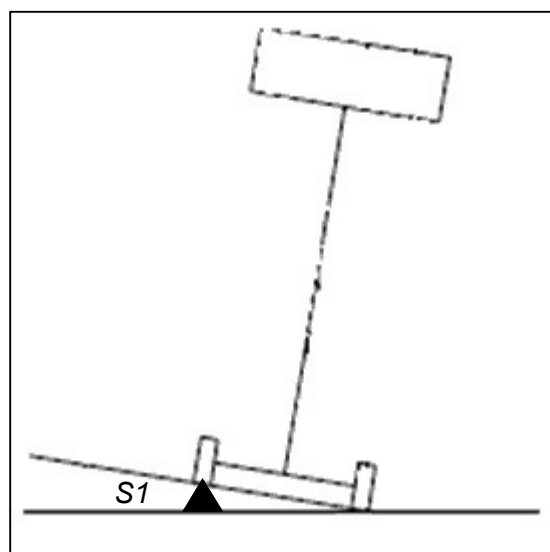

$S1 = 30$ mm

Then start the platform. The warning buzzer should begin to operate and the tilt limit angle (see figure below) indicator should come on and be STEADY



Maximum inclination indicator light

Lift the basket with the button and make sure the automatic levelling system brings the platform back to horizontal. Perform the test in the 2 directions.

CHECK WITH 1° OF LATERAL INCLINATION

Tilt the platform by placing the shims indicated in the figure below, underneath the tracks near the roller centre line (inclination reached $>1^\circ$):

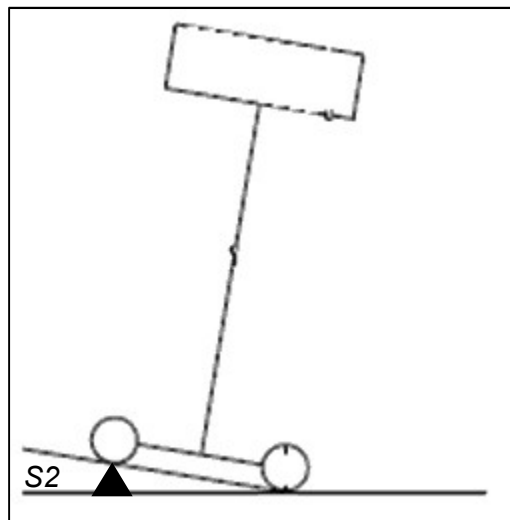

$S2 = 61 \text{ mm}$

Then start the platform. The tilt limit angle (see figure below) indicator shall flashing. The indicator is steady ON over 3° .



Maximum inclination indicator light

Lift the basket with the button and make sure the automatic levelling system brings the platform back to horizontal. Perform the test in the 2 directions.

6.12 Verify functionality of the electronic positioning inclinometer

With the descriptions in the general table, perform the verification operation of the electronic positioning inclinometer installed below the basket by means of the following controls:

A) TRANSPORT HEIGHT

- Configure the platform right above the transport height (surface > 2m);
- At this point the following conditions should be met:
 - the platform can no longer be levelled

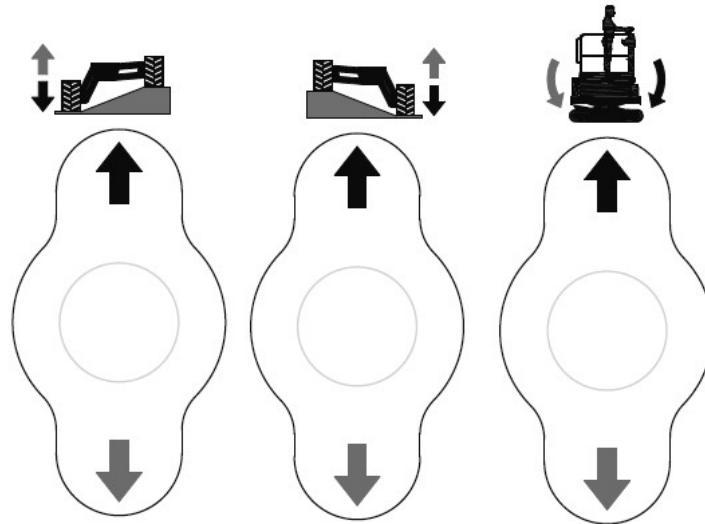

If the operation described in the previous step results as indicated, it means that the security of the inclinometer is working correctly.

REPEAT THE OPERATION DESCRIBED ABOVE LEVELLING THE OTHER TRACK AND PERFORMING LONGITUDINAL LEVELLING IN BOTH DIRECTIONS.

B) ANTI-CRUSHING

This test is performed by lowering the platform from a >2 m floor height and by checking the following conditions:

- that descent stops automatically at a preset point
- between the outer ends of the scissor here there is a space > 50 mm (check with a measuring tape)

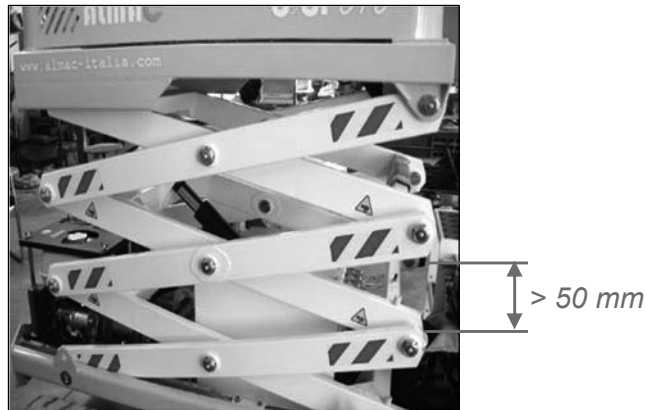

- A buzzer warns when this operation is in progress.
- **A wait time of approximately 3 seconds has been included** to allow the operator to check for the absence of bystanders in the danger zone if the “platform descent” button remains depressed once the anti-crushing position has been reached. The aforementioned audible warning devices and indicator lights continue to operate during this period of time.

If the operation described in the previous step results as indicated, it means that the security of the inclinometer is working correctly.

6.13 Electrical insulation monitoring device operation test

Check the operation of the device that monitors the electrical insulation of the 220V power supply (inverter) at the frequencies indicated in the general chart.

If the test is performed with the combustion engine running, the switch (1) in the console must be in the "OUT 220V" position. This enables 220V voltage to be supplied to the socket alongside the console. Using the special tool, remove the protective casing from the electrical panel (2) which holds the electrical isolation control device (3). Find the monitoring device (3) and press the push-button installed on the front of the residual current circuit-breaker (4), generally indicated by the word "test". This simulates an abnormal situation and automatic voltage release by the device.

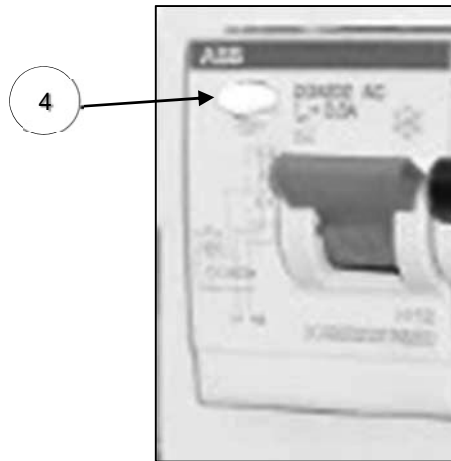
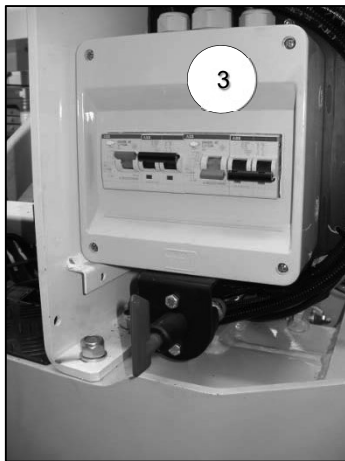
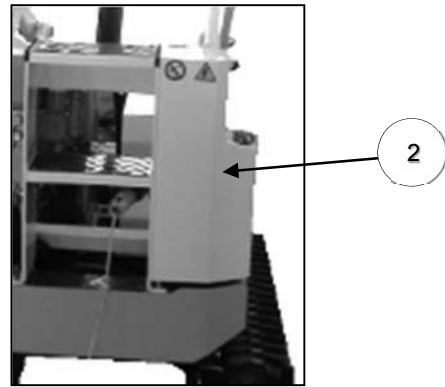
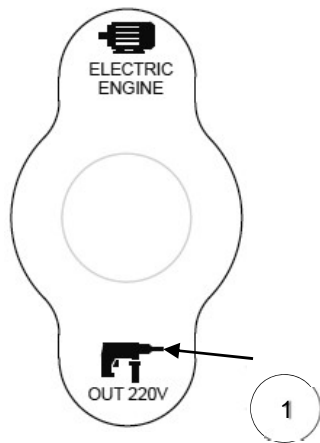

6.14 Manual emergency device operation test

Test the operation of the manual EMERGENCY DESCENT device at the inspection frequency indicated in the general chart.

An emergency push-button, marked by a decal, is installed near the ladder and, once pressed, allows the platform to lower in any condition, i.e.:

- with the combustion engine off
- when the electrical system is faulty or off
- in the absence of battery voltage



ATTENTION: THIS MECHANISM MUST ONLY BE USED IN AN EMERGENCY, i.e. ELECTRICAL OR HYDRAULIC FAILURE.

6.15 Engine oil inspection and changing

HONDA ENGINE

Check the engine oil as described below at the inspection frequency indicated in the general chart:

- 1) the oil level must be checked when the engine is off and the machine on a flat surface
- 2) remove the fill/dip-stick plug and clean the dip-stick
- 3) insert the plug with the dip-stick into the fill hole without screwing it down. Remove it and check the oil level.
- 4) If the level is near to the lower-limit notch on the dip-stick, top up with the recommended oil until the level reaches the top-limit notch. Do not over-fill.

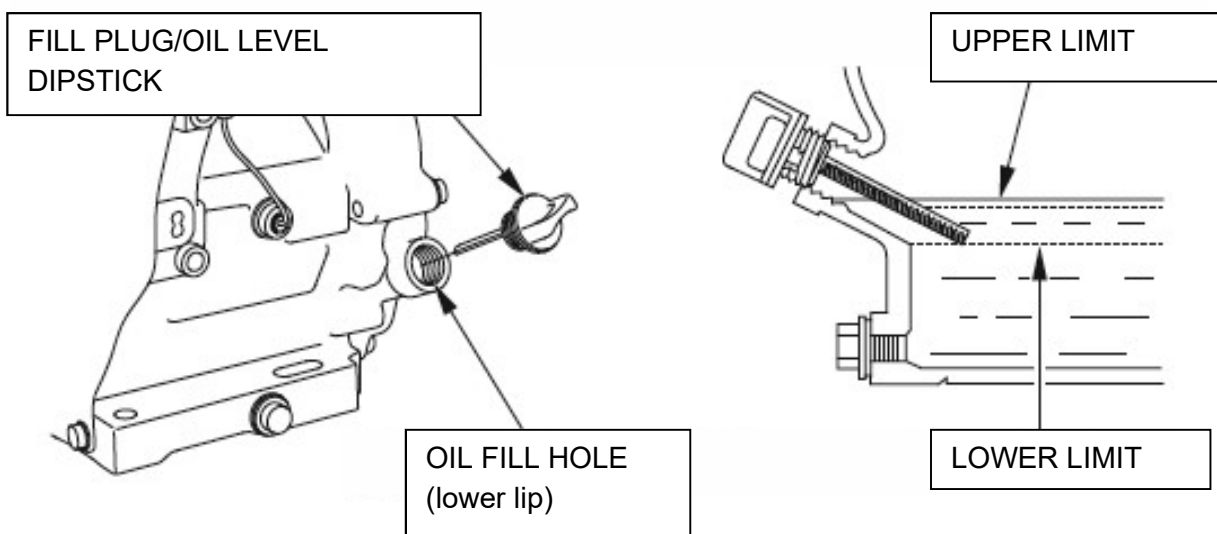

HOW TO CHANGE THE ENGINE OIL

Change the engine oil as described below at the inspection frequency indicated in the general chart:

- 1) drain out the used oil while the engine is hot (the oil will drain out faster and more completely)
- 2) place a suitable vessel under the engine so that the used oil can drain into it. Now remove the fill plug with the dip-stick, the oil drain plug and the washer.
- 3) Allow the used oil to drain out completely, then screw the oil drain plug back in place with a new washer and fully tighten it.
- 4) With the engine in a level position, fill the tank with the recommended type of oil until it reaches the top-limit notch on the dip-stick (lower edge of the oil fill hole).
- 5) Fit the fill plug with the oil level dip-stick back in place and fully tighten it.

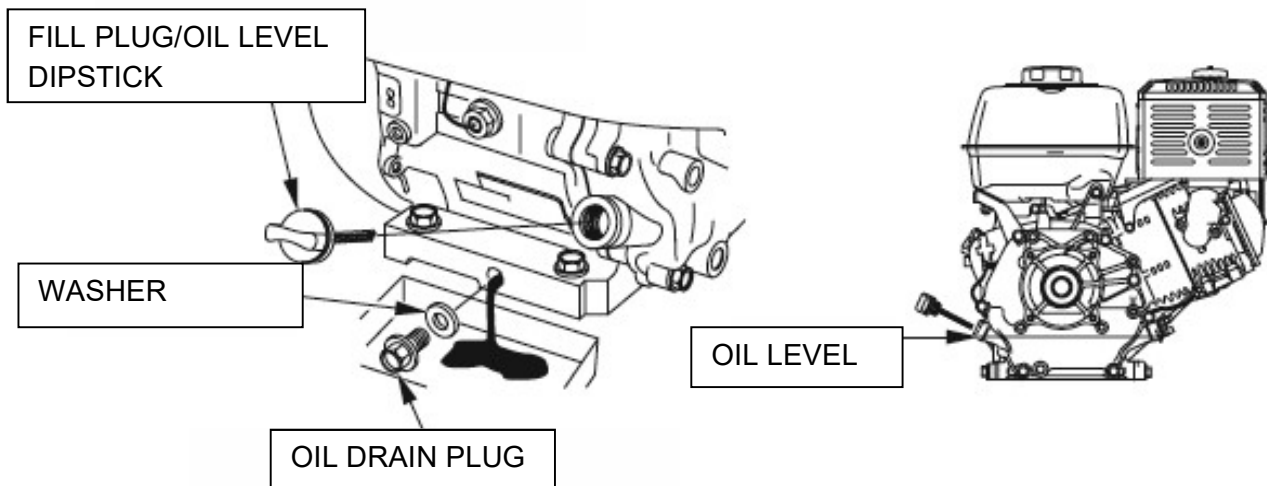

Do not reuse used oil. Do not dispose of it in the environment. Used oil must be disposed of as required by the laws in force.

RECOMMENDED OIL

Generally speaking, it is advisable to use SAE 10W-30 oil (Honda indications), SAE 15W-40 (Hatz).

- Use oil for 4-stroke engines that at least conforms to the requirements for class API SJ onwards.
- Always check the API label on the oil receptacle to make sure that it contains letters SJ or those of successive classes.

HATZ ENGINE

Engine oil

All oil brands that meet at least one of the following specifications are suitable:

- **ACEA – B2 / E2** or better
- **API – CD / CE / CF / CF-4 / CG-4** or better

If engine oils of a low quality standard are used, the oil change interval must be reduced to 150 operating hours.

Oil viscosity

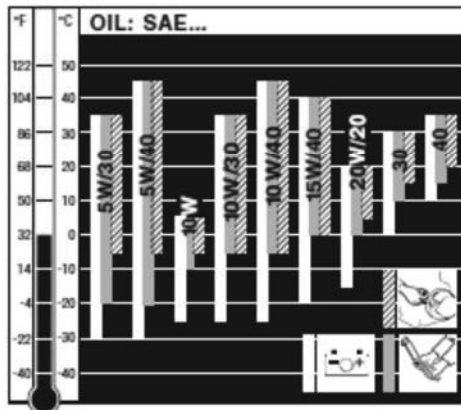

Choose the recommended viscosity based on the type of start (recoil, crank-handle or electric) and on the engine temperature at which the engine will be operated.

CAUTION	
	<p>Engine damage from unsuitable engine oil.</p> <p>Using engine oil that does not meet the above specifications considerably shortens the engine service life.</p>

Checking the oil level and adding oil if necessary

Safety notes

CAUTION	
	<p>Danger of burns.</p> <p>There is a danger of burns when working on a hot engine.</p> <ul style="list-style-type: none"> Wear safety gloves.
	<p>CAUTION</p> <p>Danger of later engine damage.</p> <ul style="list-style-type: none"> Operating the engine with an oil level below the min. mark or above the max. mark can lead to engine damage. When checking the oil level, the machine must be horizontal and the engine must be switched off.

Engine oil level

Overview

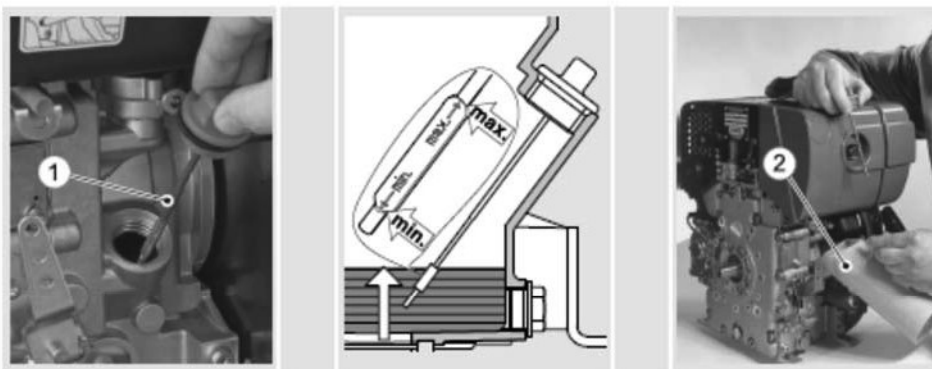





Pos.	Designation
1	Dipstick
2	Oil refilling container

Procedure

Step	Activity
1	Switch off the engine and wait several minutes for the engine oil to collect in the crank housing. The machine must be horizontal.
2	Remove contamination on the engine in the area of the dipstick.
3	Unscrew the dipstick and clean it.
4	Reinsert the dipstick and screw it tight.
5	Unscrew the dipstick and check the oil level.
6	If the oil level is close to the min. mark, add engine oil to the max. mark.
7	Reinsert the dipstick and screw it tight.

Change the engine oil

Safety notes

 CAUTION	
 	<p>Danger of burns. When working on the engine there is a danger of burns from hot oil.</p> <ul style="list-style-type: none">▪ Wear personal protective equipment (gloves).▪ Collect the used oil and dispose of it according to local environmental regulations.
NOTICE	
	<ul style="list-style-type: none">▪ The engine must be level.▪ The engine must be switched off.▪ Only drain engine oil while it is warm.▪ The engine oil should be changed when the oil filter is cleaned (see the chapter 8.2.5 <i>Clean the oil filter</i>, page 54), since oil will run out when the filter is pulled out.

Overview

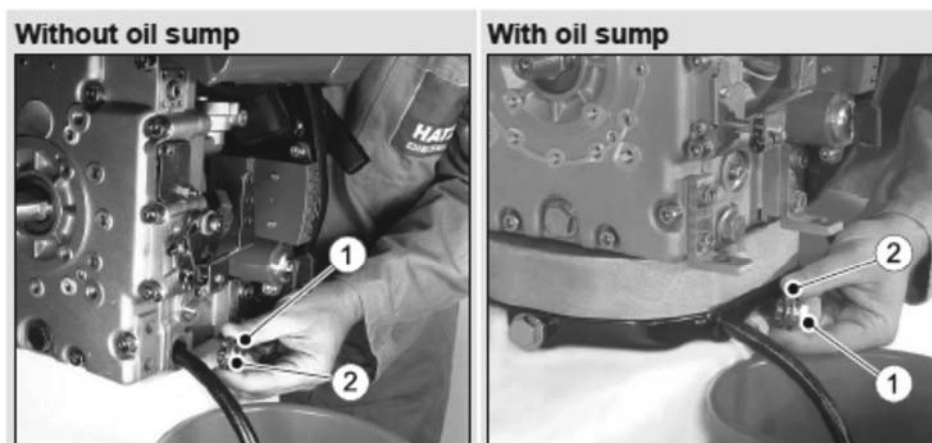







Pos.	Designation
1	Oil drain screw
2	Gasket

Procedure

Step	Activity
1	Unscrew the oil drain screw (1) and drain the oil entirely.
2	If necessary (every 1000 operating hours), clean the oil filter as per chapter 8.2.5 <i>Clean the oil filter</i> , page 54.
3	Screw in the cleaned oil drain screw (1) with the new gasket (2) and tighten. Tightening torque: 50 Nm.
4	Add engine oil (see the chapter 4.3 <i>Engine oil</i> , page 24).

Clean the oil filter

Safety notes

 CAUTION	
	Danger of burns. There is a danger of burns when working on a hot engine. <ul style="list-style-type: none">▪ Let the engine cool before maintenance.
 CAUTION	
 	Danger of injury. When working with compressed air, foreign bodies may fly into your eyes. <ul style="list-style-type: none">▪ Wear safety goggles.▪ Never direct the compressed air jet toward people or toward yourself.
NOTICE	
	<ul style="list-style-type: none">▪ Capture emerging oil in a suitable container.▪ Dispose of the oil according to legal regulations.

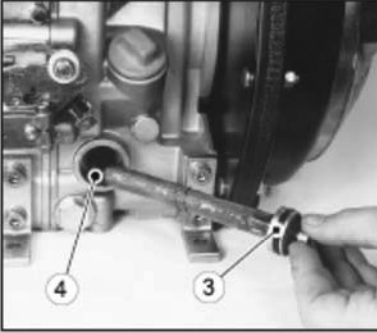
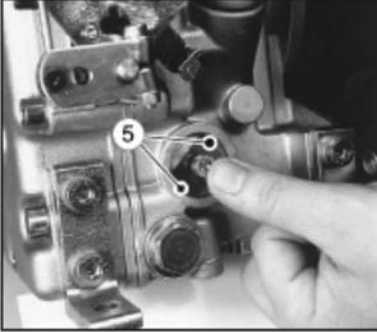
Step	Activity	Figure
4	Check the gasket (3) for damage and renew if necessary.	
5	Lightly oil the gaskets (3+4) before mounting.	
6	Insert the oil filter and press it all the way in.	
7	Before tightening the screw, ensure that the tension springs (5) rest against the oil filter at both ends. Tighten the screw.	
8	Check the oil level and add oil to the max. mark if necessary (see the chapter 4.3 <i>Engine oil</i> , page 24).	

6.16 Air filter cleaning and replacement

A dirty air filter will limit the flow of air towards the carburettor and reduce engine performance. If the engine is used in very dusty places, the air filter must be cleaned more frequently than specified in the general maintenance chart.

To CHECK and CLEAN the air filter, first remove the screws from the engine casing (1) then remove the air filter cover and inspect the filter elements.

To CLEAN (see figure below):

- 1) remove the nut from the filter cover and then remove the cover
- 2) remove the wing nut from the air filter and remove the filter
- 3) remove the foam filter from the paper filter
- 4) Inspect both filter elements and replace them if damaged. The paper element must always be replaced every YEAR or after every 300 HOURS SERVICE.
- 5) Clean the air filter elements if they must be reused.
 - a. **Paper element:** tap the filter element several times on a hard surface to remove dust, or blow compressed air from the inside of the filter element. DO NOT USE BRUSHES for cleaning as dust could penetrate into the fibres.
 - b. **Foam element:** clean in warm soapy water, rinse and allow to dry perfectly. Alternatively, use a non-flammable solvent and allow to dry. Immerse the filter in clean engine oil, and then squeeze to remove the excess oil.
- 6) Clean the dirt from inside the filter housing and cover using a damp cloth. Prevent dirt from penetrating into the air duct that leads to the carburettor.
- 7) Place the foam filter element on the paper filter element, then fit the assembled filter back in place. Make sure that the gasket is in position under the air filter, and then fully tighten the wing nut of the air filter.
- 8) Fit the air filter cover back in place and fully tighten the wing nut.

HONDA ENGINE

DOUBLE STANDARD FILTER ELEMENT

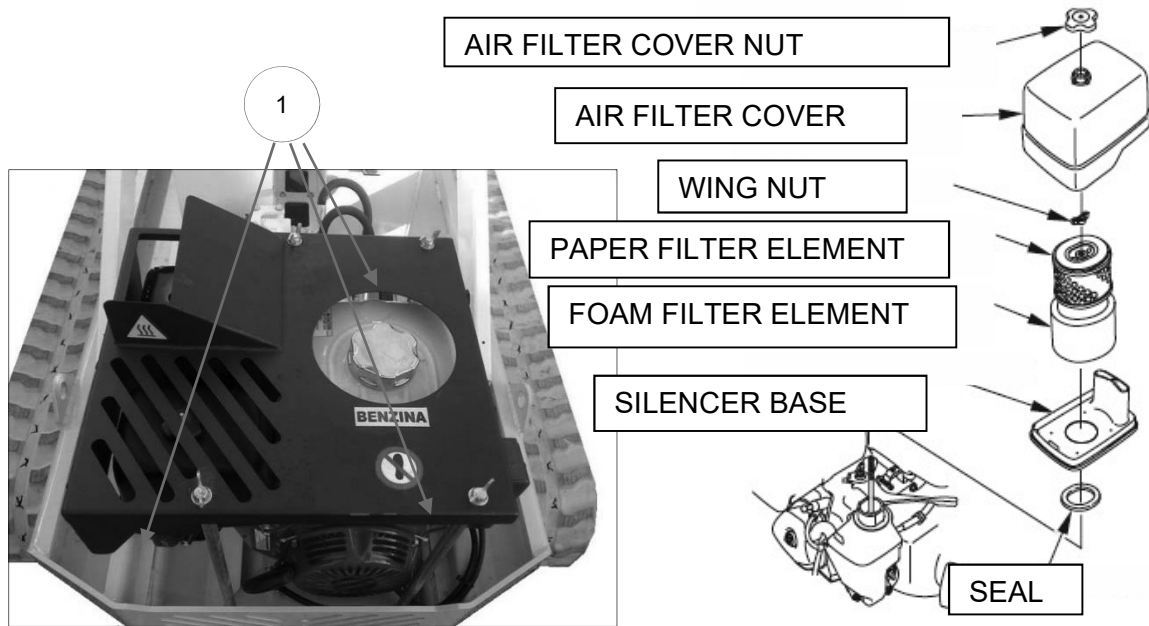

HATZ ENGINE

Maintaining the dry air filter

NOTICE



- Immediately clean the filter cartridge if the maintenance display appears at maximum speed.
- Renew the filter cartridge after a use period of 500 operating hours.

Procedures

The dry air filter is maintained in a series of steps that depend on how the engine is equipped:

- Check the air filter maintenance indicator (additional equipment).
- Installing and removing the filter cartridge

Checking the air filter maintenance indicator (additional equipment)

In a dusty environment, check the rubber bellow several times a day.

Step	Activity	Figure
1	Bring the engine briefly to maximum speed.	

Step	Activity	Figure
2	Maintain the dry air filter when the rubber bellow contracts and covers the green field (1).	



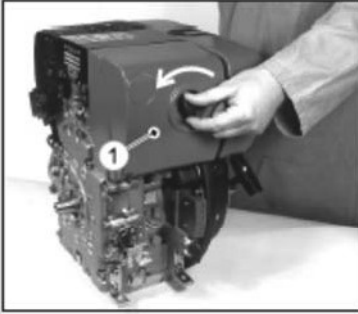
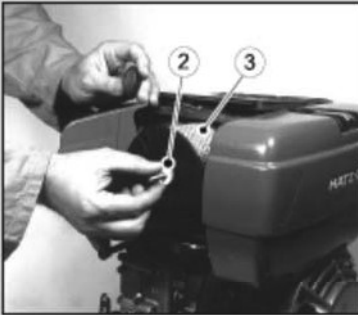
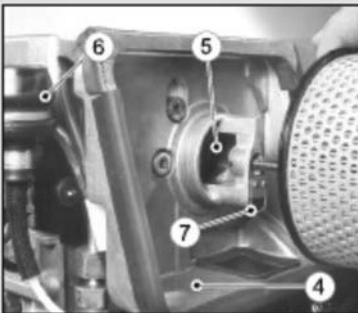

Installing and removing the filter cartridge

Step	Activity	Figure
1	Unscrew the air filter cover(1).	
2	Unscrew the knurled nut (2) and remove the air filter cartridge (3).	
3	Clean the filter housing (4) and cover for the air filter. Ingress of dirt or other foreign bodies into the intake opening (5) of the engine absolutely must be avoided.	

Step	Activity	Figure
4	In the model with an air filter maintenance display (6), check the condition and cleanliness of the valve shim (7).	
5	The air filter cartridge either needs to be replaced, or cleaned or checked depending on the degree of contamination (see the chapter 8.2.13 <i>Checking and cleaning the air filter cartridge</i> , page 75).	
6	Assemble in reverse order.	

Checking and cleaning the air filter cartridge

Safety notes

 CAUTION	
	Danger of injury. When working with compressed air, foreign bodies may fly into your eyes.
	<ul style="list-style-type: none"> Wear safety goggles. Never direct the compressed air jet toward people or toward yourself.
NOTICE	
	<ul style="list-style-type: none"> The pressure must not exceed 5 bar. Even minor damage in the areas of the sealing surface, filter paper or filter cartridge makes it impossible to reuse the filter cartridge.

Checking and cleaning the air filter cartridge

Step	Activity	Figure
Dry contamination		

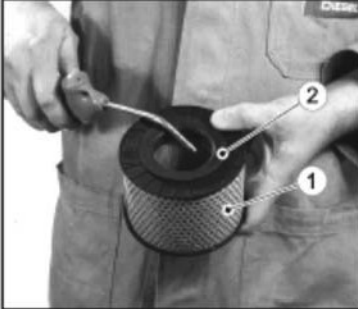
Step	Activity	Figure
1	Blow out the filter cartridge (1) with dry compressed air from the inside to the outside until dust no longer emerges.	
2	Check the sealing surface (2) of the filter cartridge for damage.	
3	Check the filter cartridge for cracks in the filter paper and other damage by holding it against the light at a slant or letting light from a lamp shine through it.	
4	Replace the filter cartridge if necessary (see note).	
Moist or oily contamination		
1	Renew the filter cartridge.	

6.17 Spark plug inspection and replacement (only Honda engines)

To obtain a good performance, the gap between the electrodes of the spark plug must be correct and it must be free from deposits. Comply with the instructions below:

- 1) remove the spark plug cap and clean off the dirt around the spark plug itself
- 2) remove the spark plug with a 13/16-inch wrench
- 3) visually inspect the spark plug and replace it if it is very worn or soiled, if the washer is in a bad condition or if the electrode is worn
- 4) measure the gap between the spark plug electrodes with a wire gauge. Correct the distance as required, by carefully bending the side electrode. The gap between the electrodes should be 0.7-0.8 mm.
- 5) Carefully install the spark plug by hand to avoid screwing it in badly.
- 6) Once the spark plug has been housed, tighten it with a 13/16-inch spark plug wrench so as to compress the washer.

NEW SPARK PLUG= tighten 1/2 of a turn once the spark plug has been housed, so as to compress the washer

ORIGINAL SPARK PLUG= tighten 1/4-1/8 of a turn once the spark plug has been housed, so as to compress the washer

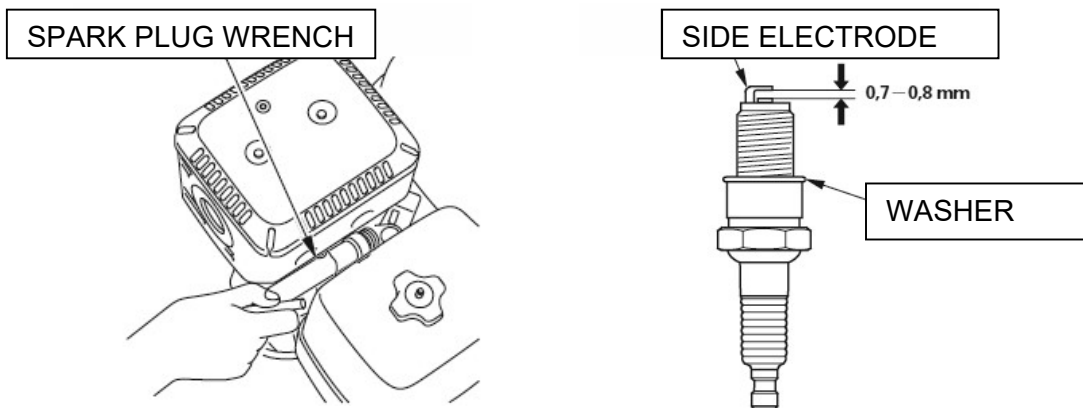

RECOMMENDED SPARK PLUGS

BPR6ES (NGK)

W20EPR-U (DENSO) (Honda indications)



A spark plug that is too loose can overheat and damage the engine. The tip thread could be damaged if the spark plug is tightened too much.

6.18 Track inspection and tensioning

Check track tension at the inspection frequency indicated in the general chart.

If the track sags and becomes too noisy as it moves, it must be tightened as described below:

- 1) Remove the guards (1)
- 2) For proper track tension use a tensioning kit (2) - not included - and pump grease in the tensioning valve (3) until it reaches the pressure indicated below. Consult the grease chart on the next pages for the type of grease required.

Max pressure track tensioning	Bar	200
--------------------------------------	------------	------------

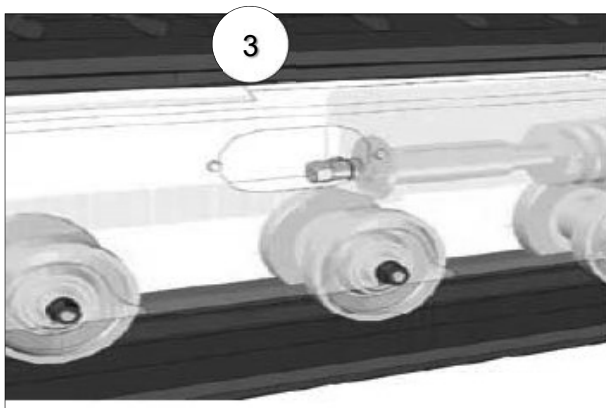
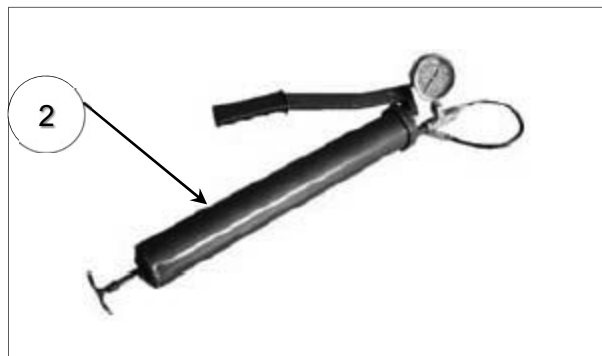
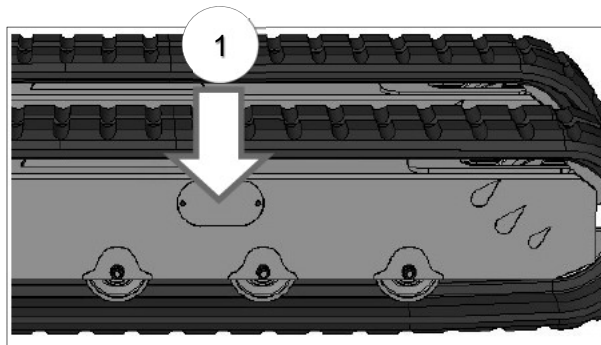

(I) TABELLA GRASSI (GB) GREASE CHART

(Il grasso normalmente utilizzato dal costruttore è PAKELO)
(The grease generally used by the Manufacturer is PAKELO)

Grasso Grease	°C -10 ÷ 40
PAKELO	Bearing EP Grease NLGI 2
BP	Grease LTX2
CASTROL	LM2 - Speerol APT 2
SHELL	Alvania GR.R.2
ESSO	Beaon 2
VALVOLINE	Lithium 20
ELF	Traslube LI Grease 2

6.19 Track inspection and replacement

Check the wear and condition of the tracks, replacing them when the **tread is equal to or less than 10 mm.**

The tracks must be changed even before they reach this limit if they are cuts or tears are noted.

The photo below shows how tread can be measured (on a car tyre in this particular case).



Tracks must only be replaced by specialized, properly trained personnel.

Comply with the “track replacement” procedure illustrated on the following pages (supplier's indications)
--

TRACK REPLACEMENT PROCEDURE

WARNING: It is forbidden to open the reduction gear unit for any operation other than routine maintenance. The manufacturer declines all liability for operations that are not part of routine maintenance and that have caused damage to persons or things.

Contact a specific assistance centre if necessary.

Track replacement:

The tracks must be replaced when the tread has worn down to 10 mm or even sooner if cuts are noted. Proceed as described below:

- 1) Do not raise the machine too far from the ground (30-40 cm are sufficient). Use the stabilizers if the machine is equipped with them, or use a jack as indicated in section 3.1.

WARNING: Make sure that the machine is in a stable position.

- 2) Thoroughly clean the undercarriage.
- 3) Remove the side clamp from the longitudinal frame member (Figure 10).

Some models are not equipped with this component (Figure 11).



Figura 10



Figura 11

62/73

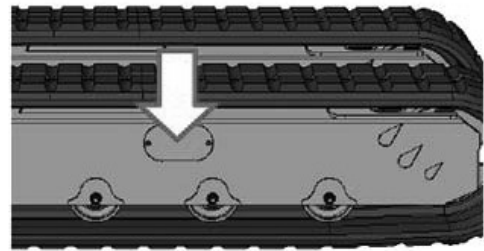
- 4) Loosen the tensioning valve.
- 5) Only disassemble the tensioning valve when the grease is no longer under pressure (see Figure 12).

(See Figure 13).

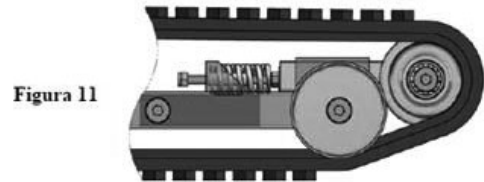
Fully screw in the supplied nut (point A) until it compresses the spring, on both the rh and lh sides of the chassis.

- 6) Retract the front wheel by pressing on the track with your foot.



Figura 12



Figura 13

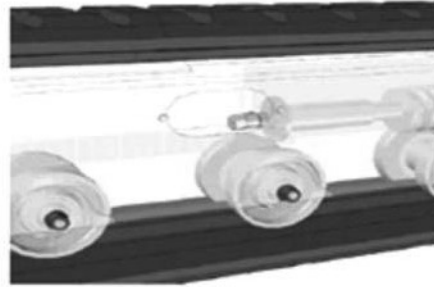

63/73

WARNING:

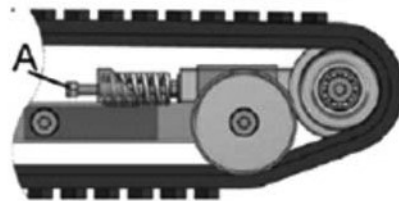
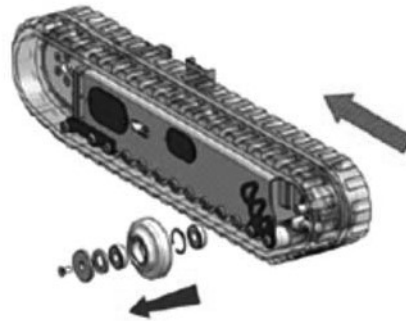
- Use personal protective equipment.
- Take particular care when the track drops to the ground.

- 7) Raise the track to the lower centre line.
- 8) Slip the track out of its housing (outwards) by levering between it and the idle wheel.

WARNING: use personal protective equipment when performing this operation.

- 9) Work through the instructions in the previous points in reverse order to install the new track.
- 10) (Ref. Figure 14) Correct track tension is obtained by using the tensioning kit and pumping grease until reaching the pressure indicated in the technical data sheet. Consult the grease chart in the Lubrication Instructions chapter (§ 5.2) for the type of grease required.

(Ref. Figure 15) The right track tension in undercarriage models equipped with tensioning screw is obtained by loosening the nut indicated in the figure and checking with a measure to make sure that spring compression is as indicated in the technical data sheet.

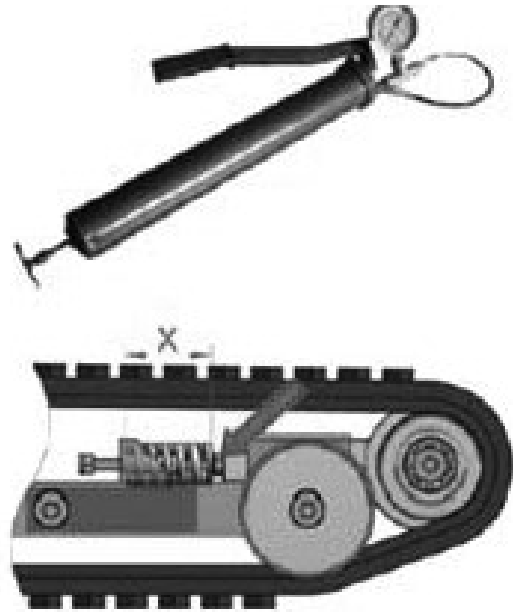

technical data sheet for the correct pressure
els with the screw tensioning device.

It is forbidden to open the reduction gear unit for any operation other than routine maintenance. The manufacturer declines all liability for operations that are not part of routine maintenance and that have caused damage to persons or things. Contact a specific assistance centre if necessary.

The components listed below must be replaced within the 100% wear limit.

6.20 Track reduction gear oil level inspection

Check the level of the oil in the track reduction gears at the frequencies given in the general chart. Comply with the procedure described below.

HOW TO CHECK AND TOP UP THE REDUCTION GEAR OIL

Before proceeding, check the drawings below to find out which type of reduction gear unit is installed in your undercarriage.

Reduction gear lubrication:

The reduction gears are normally supplied without oil. The user must choose the type of lubricant depending on the indications given in the chart below.

NOTE: Each driving wheel reduction gear model has 2 oil plugs positioned at various angles, just two examples of which are illustrated here.

Reduction gear position

Turn the reduction gear until the level plug is in pos. "A", approx. 15° below the centre line of the reduction gear, as shown in the figure alongside.

Filling and level

- Pour oil into the reduction gear through the hole in pos. B until it spills from the level hole in pos. "A", then fit the plugs back in place.
- Allow the reduction gear to turn a few times so as to eliminate any air pockets, then check the various levels again.

Filling and level

This reduction gear can be installed either horizontally or vertically.

HORIZONTAL INSTALLATION (Figure 6)

- Pour oil into the reduction gear through the hole in pos "1" until it spills from the level holes in pos. "2" or "4", then fit the plugs back in place.

VERTICAL INSTALLATION (Figure 7)

- Pour oil into the reduction gear through the hole in pos. "1" or "4" until it spills from the level hole in pos. "3", then fit the plugs back in place.
- Pour oil into the reduction gear through the hole in pos "A" until it spills from the level hole in pos. "C", then fit the plugs back in place.

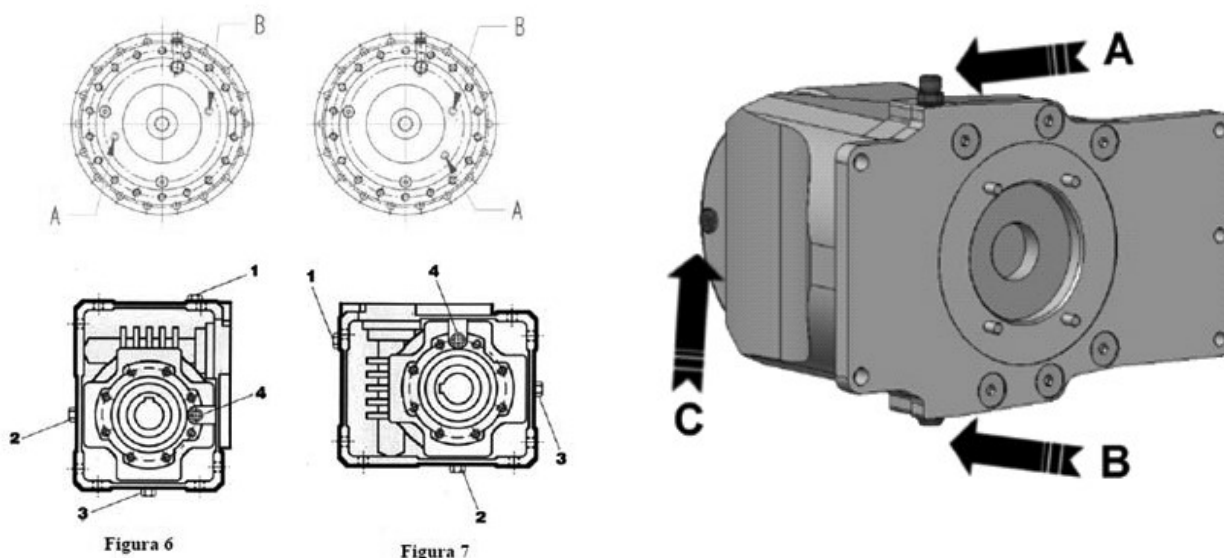

(I) TABELLA OLII PER INGRANAGGI (PER RIDUTTORE)
(GB) OIL TABLE FOR THE GEARS (FOR THE GEAR UNIT)

(L'olio normalmente utilizzato dal costruttore è PAKELO)
 (The oil generally used by the Manufacturer is PAKELO)

Lubrificante Lubricant	-20C +5C IV 95 min	-5C +30C IV 95 min	+30C +50C IV 95 min	+30C +65C IV 95 min
PAKELO	Eurolobe EP C ISO100	Eurolobe EP C ISO150	Eurolobe EP C ISO320	Eurolobe EP C ISO460
ESSO	Spartan EP 100	Spartan EP 150	Spartan EP 320	Compressor Oil LG 150
AGIP	Blasia 100	Blasia 150	Blasia 320	Blasia SX 220
ARAL	Degol BG 100	Degol BG 150	Degol BG 320	Degol BG 220
BP MACH	GR HP 100	GR HP 150	GR HP 320	GR HP 220
CASTROL	Alpha SP 100	Alpha SP 150	Alpha SP 320	Alpha SN 6
ELF	Reductelf SP 100	Reductelf SP 150	Reductelf SP 320	Oritis 125 MS Syntherma P30
CHEVRON	Non leaded gear Compound 100	Non leaded gear Compound 150	Non leaded gear Compound 320	
GULF		EP lubricant HD 150	EP lubricant HD 320	
I.P.	Mellana 100	Mellana 150	Mellana 320	Mellana Oil 100
MOBIL		Mobilgear 629	Mobilgear 632	Glycoyle 22/30 SHC 630
SHELL	Omala Oil 100	Omala Oil 150	Omala Oil 320	Omala Oil SA
TOTAL	Carter EP 100N	Carter EP 150N	Carter EP 320N	
KLUBER	Lamora 100	Lamora 150	Lamora 320	
ISO 3448	VG100	VG150	VG320	VG150-200

6.21 How to clean the machine

The machine can be cleaned with jets of NON-PRESSURIZED water. Take care to protect all the parts marked by decals:



Plus:

- the control console
- the casings that contain the electric panels and control systems
- the safety switches

6.22 Refuelling

The Honda GX-390 engine is certified for use with unleaded gasoline with an octane rating of at least 86 (octane number (RON) at least 91).

Refuel as described below:

- 1) With the engine off and on a level surface, remove the fuel tank cap (1) and check the level (2). If the level is low, the tank must be topped up.
- 2) Add fuel up to the lower edge of the maximum tank fuel level limit (2). Do not overfill and dry off any spilt fuel before starting the engine.
- 3) Refuel carefully to avoid fuel spills. After refuelling, tighten the fuel cap (1).

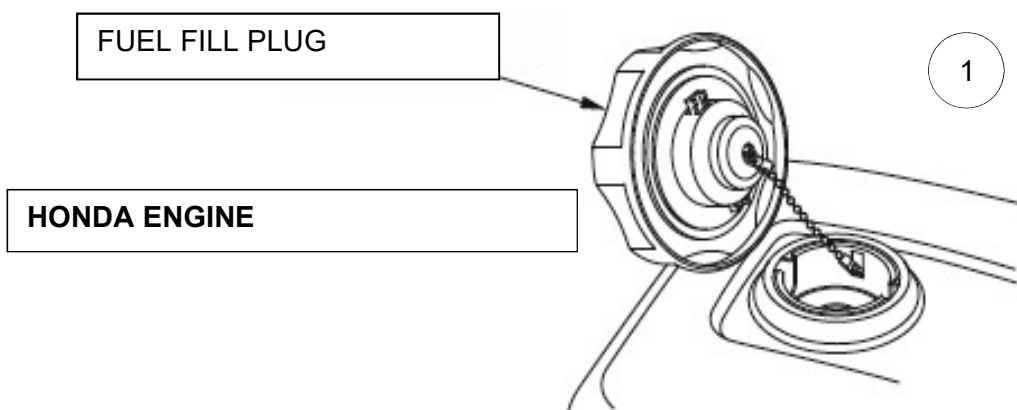

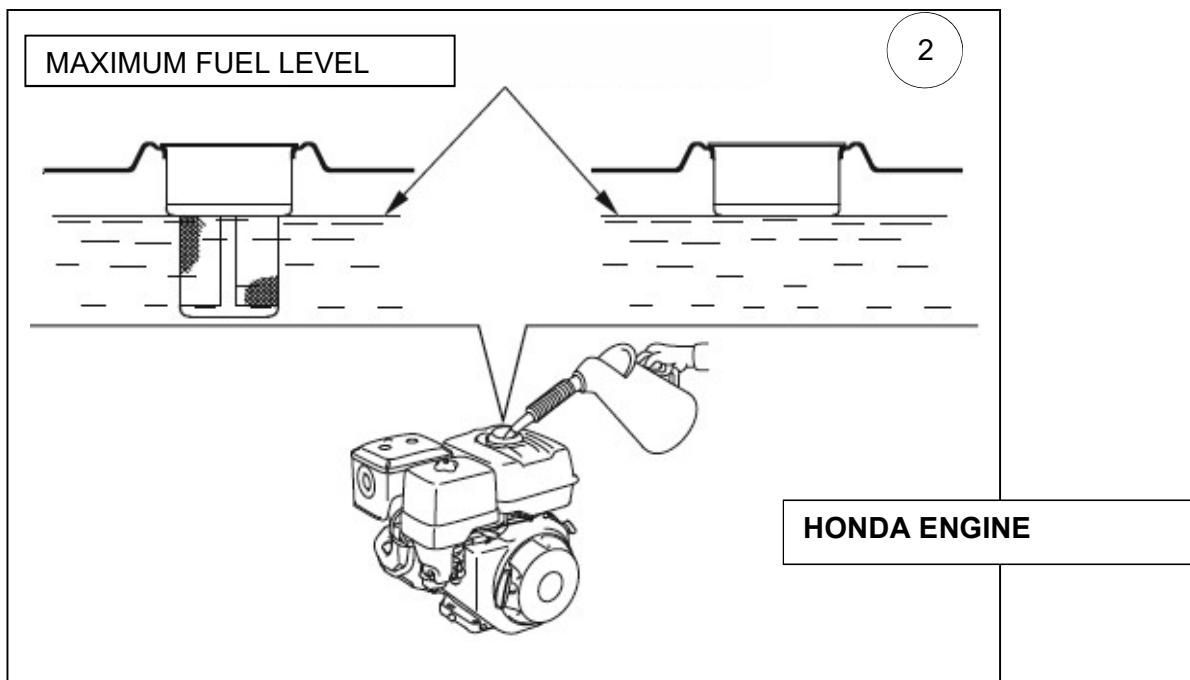

Danger: keep fuel well away from the indicator lights of equipment, household appliances, heat sources and sources of ignition.



Danger: Spilt gasoline is a fire hazard and also a source of environmental pollution. Spilt fuel must be immediately wiped up and dried.

HATZ ENGINE

Fuel type

All types of diesel fuel that meet the minimum requirements of the following specifications are suitable:

- EN 590 or
- BS 2869 A1 / A2 or
- ASTM D 975- 1D / 2D

CAUTION	
	<p>Danger of engine damage from low quality fuel.</p> <p>The use of fuel that does not meet the specifications can lead to engine damage.</p> <ul style="list-style-type: none">• The use of fuel that does not meet specifications requires approval by Motorenfabrik HATZ (main plant).



Winter fuel

When outside temperatures drop below 0 °C, use winter fuel or mix in petroleum in advance:

Lowest ambient temperature at start [°C]	Percentage of petroleum [%] for	
	Summer fuel	Winter fuel
0 to -10	20	-
-10 to -15	30	-
-15 to -20	50	20
-20 to -30	-	50

Refueling

Safety notes

 DANGER	
 	<p>Fire hazard from fuel.</p> <p>Leaked or spilled fuel can ignite on hot engine parts and cause serious burn injuries.</p> <ul style="list-style-type: none">• Only refuel while the engine is switched off.• Never refuel in the vicinity of open flames or sparks that can cause ignition.• Do not smoke.• Do not spill fuel.

CAUTION



Danger of environmental damage from spilled fuel.

Do not overfill the fuel tank and do not spill fuel.

- Collect emerging fuel and dispose of it in an environmentally compatible manner.

CAUTION

Engine damage from using low quality fuel.

The use of fuel that does not meet the specifications can lead to engine damage.



- Only use the fuel specified in the chapter 4.2 *Fuel*, page 24.
- The use of fuel that does not meet specifications requires approval by Motorenfabrik HATZ (main plant).

Overview



Pos.	Designation
1	Fuel cap
2	Fuel tank

Procedure

Step	Activity	Figure
1	Open the fuel cap.	
2	Fill the fuel tank with diesel fuel.	
3	Close the fuel cap.	

NOTICE



- Before starting for the first time or if the fuel system is empty, fill the fuel tank fully with diesel fuel. This causes the fuel system to be bled automatically.
- Automatic bleeding is completed after a waiting period of 1-2 minutes. The engine is ready to start.

7.1 Decommissioning and demolition

Once it has reached the end of its technical life, the machine must be decommissioned and then demolished. The machine must be reduced to conditions in which it can no longer be used for the purposes for which it was designed and built. In addition, the raw materials used to make it must be recovered for recycling purposes where possible.



Note: ALMAC S.r.l. declines all liability for damage to persons, animals or things deriving from reuse of parts of the equipment for functions or assembly situations differing from the original ones.



Danger: Decommissioning and demolition of the machine must only be performed by properly trained and equipped personnel.

The machine must be demolished following the adoption of safety measures that must take account of the logistic, environmental and wear conditions of the machine itself.

Comply with the following general rules:

- wear approved protective clothing and accessories (hard-hat, safety footwear, gloves, goggles and face mask if necessary) in accordance with the accident-prevention laws in force.
- Disconnect the machine from all power sources.
- Check and, if necessary, relieve the pressure from pressurized systems.
- Ensure that the machine is unable to operate and that it cannot be used, by breaking some of its vital components and take it to a place where you are certain that it cannot be accessed by anyone.
- Use appropriate lifting equipment as described in sec. 2.5-*Transport and loading*
- Disassemble the machine into small, easily transportable units.
- Separate non-polluting materials from polluting ones when disposing of the machine (insulating materials, plastic, rubber, etc.).
- Never burn the machine or parts of it because the combustion products of plastic materials and paints could develop harmful, polluting gases.

Declaration of conformity



Declaration of Conformity

Original declaration

ALMAC S.r.l.
Viale Ruggeri 6/a
c.a.p. 42016, Guastalla (RE) - Italia
Tel 0522-1495846
http: www.almac-italia.com
e-mail: info@almac-italia.com
P.IVA e Cod.Fisc. 02559800350

Declares, under our own responsibility that the Mobile Elevating Working Platform (MEWP) :

MODEL: BIBI 850-BL
SERIAL NUMBER: ALM-000
MANUFACTURING YEAR: 2016

as described in the documentation attached to this declaration is in accordance with:

- Directive 2006/42/EC on machinery
- UNI EN 280:2015 Mobile elevating work platforms. Design calculations. Stability criteria. Construction. Safety. Examinations and tests
- UNI EN ISO 12100:2010 Safety of machinery. Risk assessment. Principles

Directive 2004/108/CE on the approximation of the laws of the member States relating to

electromagnetic compatibility

Directive 2000/14/EC (Annex I) on the noise emission in the environment of equipment for use

in the

o Measured acoustic power level (LWA): 100 dB

o Guaranteed acoustic power level (LWA): 104 dB

is the same as machine covered by EC certification (annex IV)

Facsimile

and that, in compliance with attachment IV of the Directive, each and every part of the machine has undergone the above EC-type examination performed by:

VERICERT srl - Certificazioni e Verifiche – Notified Body No. 1878
with head office in Via Cavina, 19 – 48100 RAVENNA – ITALY -
which has issued the EC-TYPE EXAMINATION CERTIFICATE:
1878M170615CT0415-INT.01 del 11.02.2016

The Legal person charged with the constitution of the Technical Dossier is:

Name: PIETRO
Surname: AGOSTA DEL FORTE
Position: Legal representative of ALMAC s.r.l.

PIETRO AGOSTA DEL FORTE
(Legal representative)

Guastalla (RE) , li 11/02/2016

(Place and Date)

(Stamp and Signature)

Appendix 2 **Report register**

A. Report register

The Report register is issued to the platform user with reference to:

- Technical standard EN280:2013
- Legislative Decree 17/2010 – Implementation of Machinery Directive 2006/42/EC

The purpose of this Register is to record events concerning the life of the machine; in detail:

- Mandatory routine inspections (INAIL, ASL, authorized bodies)
- Maintenance and obligatory inspections to check the integrity and structure of the machine and protection and safety systems (*see Chap. 6-Maintenance*)
- Transfers of ownership, to be notified to the competent INAIL (former ISPESL) department
- Supplementary maintenance or replacement of important parts of the machine

Type of inspection		Description	
Checking and tightening screws, bolts, nuts, plug ring nuts		See sect.6.2	
	Date	Observations	Signature
1st year			
2nd year			
3rd year			
4th year			
5th year			
6th year			
7th year			
8th year			
9th year			
10th year			

NOTE: Operation to be performed BEFORE EACH USE. Daily registration is not necessary, but should be made at least once a year when other operations are performed.

Type of inspection		Description	
Visual and structural inspection		See sect.6.3	
	Date	Observations	Signature
1st year			
2nd year			
3rd year			
4th year			
5th year			
6th year			
7th year			
8th year			
9th year			
10th year			

NOTE: Operation to be performed BEFORE EACH USE. Daily registration is not necessary, but should be made at least once a year when other operations are performed.

Type of inspection		Description	
Damage to tubes and cables		See sect.6.4	
	Date	Observations	Signature
1st year			
2nd year			
3rd year			
4th year			
5th year			
6th year			
7th year			
8th year			
9th year			
10th year			

NOTE: Operation to be performed MONTHLY. Monthly registration is not necessary, but should be made at least once a year when other operations are performed.

Type of inspection		Description	
Greasing of articulations and runners		See sect.6.5	
	Date	Observations	Signature
1st year			
2nd year			
3rd year			
4th year			
5th year			
6th year			
7th year			
8th year			
9th year			
10th year			

NOTE: Operation to be performed MONTHLY. Monthly registration is not necessary, but should be made at least once a year when other operations are performed.

Type of inspection		Description	
Hydraulic tank oil level inspection		See sect.6.6	
	Date	Observations	Signature
1st year			
2nd year			
3rd year			
4th year			
5th year			
6th year			
7th year			
8th year			
9th year			
10th year			

NOTE: Operation to be performed BEFORE EACH USE. Daily registration is not necessary, but should be made at least once a year when other operations are performed.

Type of inspection		Description	
Hydraulic reservoir oil change		See sect.6.7	
	Date	Observations	Signature
1st year			
2nd year			
3rd year			
4th year			
5th year			
6th year			
7th year			
8th year			
9th year			
10th year			

NOTE: Operation to be performed EVERY TWO YEARS.

Type of inspection		Description	
Inspection of lift circuit pressure relief valve operation		See sect.6.8	
	Date	Observations	Signature
1st year			
2nd year			
3rd year			
4th year			
5th year			
6th year			
7th year			
8th year			
9th year			
10th year			

NOTE: Operation to be performed ANNUALLY.

Type of inspection		Description	
Battery		See sect.6.9	
	Date	Observations	Signature
1st year			
2nd year			
3rd year			
4th year			
5th year			
6th year			
7th year			
8th year			
9th year			
10th year			

NOTE: Operation to be performed BEFORE EACH USE. Daily registration is not necessary, but should be made at least once a year when other operations are performed.

Type of inspection		Description	
Hydraulic filter replacement		See sect.6.10	
	Date	Observations	Signature
1st year			
2nd year			
3rd year			
4th year			
5th year			
6th year			
7th year			
8th year			
9th year			
10th year			

NOTE: Operation to be performed EVERY TWO YEARS.

Type of inspection		Description	
Inclinometer operation test		See sect.6.11	
	Date	Observations	Signature
1st year			
2nd year			
3rd year			
4th year			
5th year			
6th year			
7th year			
8th year			
9th year			
10th year			

NOTE: Operation to be performed ANNUALLY.

Type of inspection		Description	
Microswitch operation test		See sect.6.12	
	Date	Observations	Signature
1st year			
2nd year			
3rd year			
4th year			
5th year			
6th year			
7th year			
8th year			
9th year			
10th year			

NOTE: Operation to be performed ANNUALLY.

Type of inspection		Description	
Electrical insulation monitoring device operation test		See sect.6.13	
	Date	Observations	Signature
1st year			
2nd year			
3rd year			
4th year			
5th year			
6th year			
7th year			
8th year			
9th year			
10th year			

NOTE: Operation to be performed ANNUALLY.

Type of inspection		Description	
Manual emergency device operation test		See sect.6.14	
	Date	Observations	Signature
1st year			
2nd year			
3rd year			
4th year			
5th year			
6th year			
7th year			
8th year			
9th year			
10th year			

NOTE: Operation to be performed ANNUALLY.

Type of inspection		Description	
Engine oil inspection		See sect.6.15	
	Date	Observations	Signature
1st year			
2nd year			
3rd year			
4th year			
5th year			
6th year			
7th year			
8th year			
9th year			
10th year			

NOTE: Operation to be performed BEFORE EACH USE. Daily registration is not necessary, but should be made at least once a year when other operations are performed.

Type of inspection		Description	
HOW TO CHANGE THE ENGINE OIL		See sect.6.15	
	Date	Observations	Signature
1st year			
2nd year			
3rd year			
4th year			
5th year			
6th year			
7th year			
8th year			
9th year			
10th year			

NOTE: Operation to be performed after EVERY 100 HOURS SERVICE.

Type of inspection		Description	
Track inspection and tensioning		See sect.6.18	
	Date	Observations	Signature
1st year			
2nd year			
3rd year			
4th year			
5th year			
6th year			
7th year			
8th year			
9th year			
10th year			

NOTE: Operation to be performed BEFORE EACH USE. Daily registration is not necessary, but should be made at least once a year when other operations are performed.

Type of inspection		Description	
Track inspection and replacement		See sect.6.19	
	Date	Observations	Signature
1st year			
2nd year			
3rd year			
4th year			
5th year			
6th year			
7th year			
8th year			
9th year			
10th year			

NOTE: Operation to be performed when tread is <10 mm or if cuts are noted

Type of inspection		Description	
Track reduction gear oil level inspection		See sect.6.20	
	Date	Observations	Signature
1st year			
2nd year			
3rd year			
4th year			
5th year			
6th year			
7th year			
8th year			
9th year			
10th year			

NOTE: Operation to be performed MONTHLY. Daily registration is not necessary, but should be made at least once a year when other operations are performed.

Type of inspection		Description	
Top track roller and frame		Check condition of anchorages, supports, structures, welds, plugs and especially condition of top track roller	
	Date	Observations	Signature
1st year			
2nd year			
3rd year			
4th year			
5th year			
6th year			
7th year			
8th year			
9th year			
10th year			

NOTE: Operation to be performed EVERY SIX MONTHS. Registration every six months is not necessary, but should be made at least once a year when other operations are performed.

Type of inspection		Description	
Parking brake		Make sure that parking brake functions correctly when machine stops	
	Date	Observations	Signature
1st year			
2nd year			
3rd year			
4th year			
5th year			
6th year			
7th year			
8th year			
9th year			
10th year			

NOTE: Operation to be performed EVERY SIX MONTHS. Registration every six months is not necessary, but should be made at least once a year when other operations are performed.

Serious faults		
Date	Description of fault	Solution
Spare parts used		Description
Code	qty	

Serious faults		
Date	Description of fault	Solution
Spare parts used		Description
Code	qty	

Serious faults		
Date	Description of fault	Solution
Spare parts used		Description
Code	qty	

Property transfers

<i>Copy to be kept</i>	
on:	_____
ownership of the MEWP:	_____
serial no.	_____
Year built	_____
was transferred to:	_____
It is hereby certified that, as of the date above, the technical, dimensional and functional characteristics of the aforementioned platform conformed to the original characteristics and that variations, if any, have been recorded in the register	
Seller's business name:	
Seller	
Purchaser	

<i>Copy to send to ALMAC SRL</i>	
on:	_____
ownership of the MEWP:	_____
serial no.	_____
Year built	_____
was transferred to:	_____
It is hereby certified that, as of the date above, the technical, dimensional and functional characteristics of the aforementioned platform conformed to the original characteristics and that variations, if any, have been recorded in the register	
Seller's business name:	
Seller	
Purchaser	

Appendix 4 **Hydraulic diagram**

Appendix 5 **Circuit diagram**